

Technical Data

Specifications & Capacities

RTC 8075

Telescopic Boom Rough Terrain Crane
75 ton (68.0 metric ton)

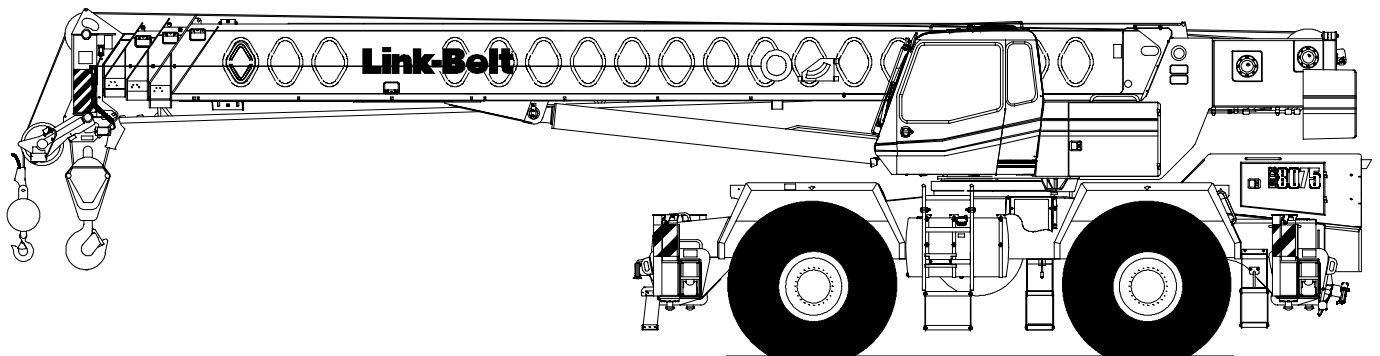

CAUTION: This material is supplied for reference use only. Operator must refer to in-cab Crane Rating Manual and Operator's Manual to determine allowable crane lifting capacities and assembly and operating procedures.

Table Of Contents

Boom, Attachments, and Upper Structure	1
Boom	1
Boom Head	1
Boom Elevation	1
Auxiliary Lifting Sheave – Optional	1
Hook Blocks and Balls – Optional	1
Fly – Optional	1
Operator’s Cab and Controls	1
Swing	2
Electrical	2
Load Hoist System	3
Load Hoist Performance	3
2M Main and Optional Auxiliary Winches	3
Hydraulic System	3
Counterweight	3
Carrier	4
General	4
Outriggers	4
Steering and Axles	4
Suspension	4
Tires and Wheels	4
Brakes	4
Electrical	4
Engine	4
Transmission	4
Carrier Speeds and Gradeability	5
Fuel Tank	5
Hydraulic System	5
Pump Drive	5
Axle Loads	6
General Dimensions	7
Working Range Diagram	8
Boom Extend Modes	9
Main Boom Lift Capacity Charts – Standard	10
15,000 lb Counterweight – Fully Extended Outriggers – 360° Rotation	10
15,000 lb Counterweight – On Tires – Stationary – Boom Centered Over Front Between Tire Tracks	11
15,000 lb Counterweight – On Tires – Pick & Carry (1 mph) – Boom Centered Over Front	11
15,000 lb Counterweight – On Tires – Stationary – 360° Rotation	11
Fly Attachment Lift Capacity Charts – Optional	12
15,000 lb Counterweight – Fully Extended Outriggers – 360° Rotation	12
127 ft Main Boom Length – 2° Fly Offset	12
127 ft Main Boom Length – 20° Fly Offset	12
127 ft Main Boom Length – 40° Fly Offset	12

Main Boom Lift Capacity Charts – Optional (Metric)	13
6 804kg Counterweight – Fully Extended Outriggers – 360° Rotation	13
6 804kg Counterweight – On Tires – Stationary – Boom Centered Over Front Between Tire Tracks .	14
6 804kg Counterweight – On Tires – Pick & Carry (1.6km/h) – Boom Centered Over Front	14
6 804kg Counterweight – On Tires – Stationary – 360° Rotation	15
Fly Attachment Lift Capacity Charts – Optional (Metric)	15
6 804kg Counterweight – Fully Extended Outriggers – 360° Rotation	15
38.71m Main Boom Length – 2° Fly Offset	15
38.71m Main Boom Length – 20° Fly Offset	15
38.71m Main Boom Length – 40° Fly Offset	15

Boom, Attachments, and Upper Structure

■ Boom

Design – Four section, box type construction of high tensile steel consisting of one base section and three telescoping sections. The vertical side plates have diamond shaped steel impressions for superior strength to weight ration. The first telescoping section extends independently by means of one double-acting, single stage hydraulic cylinder with integrated holding valves. The second and third telescoping sections extend proportionally by means of one double-acting, single stage cylinder with integrated holding valves and cables.

Boom

- 41–127 ft (12.5–38.7m) four section full power boom
- Two mode boom extension: *A-max* mode provides superior capacities by extending the first telescoping section to 69.6 ft (21.2m). Standard mode synchronizes all the telescoping sections proportionally to 127 ft (38.7m). Controlled from the operator's cab.
- Mechanical boom angle indicator
- Maximum tip height for *A-max* mode is 80 ft (24.3m) and standard mode is 136 ft (41.4m).

Boom Head

- Five 16.5 in (41.9cm) root diameter nylon sheaves to handle up to ten parts of line
- Easily removable wire rope guards
- Rope dead end lugs on each side of the boom head
- Boom head is designed for quick-reeve of the hook block

Boom Elevation

- One double acting hydraulic cylinder with integral holding valve
- Boom elevation: -3° to 78°

Auxiliary Lifting Sheave – Optional

- Single 16.5 in (41.9m) root diameter nylon sheave
- Easily removable wire rope guards
- Does not affect erection of the fly or use of the main head sheaves

Hook Blocks and Balls – Optional

- 40 ton (36.3mt) 4 sheave quick-reeve hook block with safety latch
- 60 ton (54.4mt) 4 sheave quick-reeve hook block with safety latch
- 75 ton (68.0mt) 5 sheave quick-reeve hook block with safety latch
- 8.5 ton (7.7mt) swivel and non-swivel hook balls with safety latch

Fly – Optional

- 39 ft 6 in (12.0m) one piece lattice fly, stowable, offsettable to 2° , 20° , and 40° . Maximum tip height is 174 ft (53.0m).

- 39 ft 6 in–67 ft (12.0–20.4m) two piece bi-fold lattice fly, stowable, offsettable to 2° , 20° , and 40° . Maximum tip height is 202 ft (61.6m).

■ Operator's Cab and Controls

Environmental Cab – Fully enclosed, one person cab of galvaneal steel structure with acoustical insulation
Equipped with:

- Tinted and tempered glass windows
- Extra-large fixed front window with windshield wiper and washer
- Swing up roof window with windshield wiper
- Sliding left side door with large fixed window
- Sliding rear and right side windows for ventilation
- Six way adjustable, cushioned seat with seat belt and storage compartment
- Engine dependent warm-water heater with air ducts for front windshield defroster and cab floor
- Defroster fan for the front window
- Bubble level
- Circulating fan
- Adjustable sun visor
- Dome light
- Cup holder
- Fire extinguisher
- Left side viewing mirror
- Two position travel swing lock

Air Conditioning – Optional – Integral with cab heating system utilizing the same ventilation outlets

Steering Column – Optional – Pedestal type with tilt and telescope functions for operator comfort. Column includes the following controls and indicators:

Left and right levers include:

- Horn button
- Turn signal switch
- Driving light switch
- Transmission direction switch

Panel mounted switches for:

- Travel park brake
- Steer mode selector
- 2/4 wheel drive/range selector
- Transmission gear selector
- Hazard flasher

Panel mounted indicator/warning lights for:

- Transmission temperature
- Engine oil pressure
- Travel park brake
- Service brake
- Turn signals
- Rear wheel offset
- Emergency steer – optional

Armrest Controls – Two dual axis hydraulic joystick controllers or optional single axis hydraulic controllers for:

- Swing
- Boom hoist
- Main rear winch
- Auxiliary front winch – optional
- Drum rotation indication
- Drum rotation indicator activation switch
- Winch high/low speed and disable switch(es)
- Third wrap selector switch – optional
- Telescopic override switches
- Warning horn button
- Swing park brake

Outrigger Controls – Hand held control box with umbilical cord gives the operator the freedom to view operation while setting the outriggers.

Foot Controls

- Boom telescope
- Swing brake
- Engine throttle
- Service brake

Right Front Console – Controls and indicators for:

- | | |
|-------------------------------------|---|
| • Engine ignition | • Console dimmer switch |
| • Engine throttle lock | • Bubble level |
| • Function disable | • 12 volt power connection |
| • Front windshield wiper and washer | • Air conditioning – optional |
| • Cab floodlights | • Boom floodlight – optional |
| • Warning horn | • Rotating beacon/Strobe light – optional |
| • Heating controls | • Third wrap indicator – optional |

Cab Instrumentation – Ergonomically positioned, analog instrumentation for crane operation including:

- Engine coolant temperature with warning indicator
- Hydraulic oil temperature with warning indicator
- Fuel level with warning indicator
- Tachometer
- Transmission temperature with warning indicator
- Voltmeter with warning indicator

Rated Capacity Limiter – Microguard graphic audio–visual warning system integrated into the dash with anti–two block and function limiter. Operating data available includes:

- Crane configuration
- Boom length and angle
- Boom head height
- Allowed load and % of allowed load
- Boom angle
- Radius of load
- Actual load
- Operator settable alarms (include):
 - Maximum and minimum boom angles
 - Maximum tip height
 - Maximum boom length
 - Swing left/right positions
 - Operator defined area (imaginary plane)

Internal RCL Light Bar – Optional – Visually informs the operator when crane is approaching maximum load capacity with a series of green, yellow, and red lights.

External RCL Light Bar – Optional – Visually informs the ground crew when crane is approaching maximum load capacity with a series of green, yellow, and red lights.

■ Swing

Motor/Planetary – Bi–directional hydraulic swing motor mounted to a planetary reducer for 360° continuous smooth swing at 2.1 rpm.

Swing Park Brake – 360°, electric over hydraulic, (spring applied/hydraulic released) multi–disc brake mounted on the speed reducer. Operated by a toggle switch from the operator’s cab.

Swing Brake – 360°, foot operated, hydraulic applied disc brake mounted to the speed reducer.

Swing Lock – Two–position swing lock (boom over front or rear) operated from the operator’s cab.

360° Positive Swing Lock – Optional – Meets New York City requirement.

■ Electrical

Swing Alarm – Audio warning device signals when the upper is swinging.

Lights

- Two working lights on front of the cab
- One rotating amber beacon on top of the cab – optional
- One amber strobe beacon on top of the cab – optional
- Boom floodlight – optional

■ Load Hoist System

Load Hoist Performance

Main (Rear) and Auxiliary (Front) Winches – 3/4 in (19mm) Rope										
Layer	Maximum Line Pull		Normal Line Speed		High Line Speed		Layer		Total	
	lb	kg	ft/min	m/min	ft/min	m/min	ft	m	ft	m
1	16,506	7 487.0	176	53.6	352	107.3	114	34.7	114	34.7
2	15,175	6 883.4	192	58.5	383	116.7	124	37.8	238	72.5
3	14,043	6 369.9	207	63.1	414	126.2	134	40.8	372	113.4
4	13,068	5 927.6	223	68.0	445	135.6	144	43.9	516	157.3
5	12,220	5 543.0	238	72.5	476	145.1	154	46.9	670	204.2

Wire Rope Application		Diameter		Type	Maximum Permissible Load	
		in	mm		lb	kg
Main (Rear) Winch	Standard	3/4	19	18x19 rotation resistant – right regular lay (Type RB)	12,920	5 860.5
	Optional	3/4	19	34x7 rotation resistant – right regular lay (Type ZB)	15,600	7 076.2
Auxiliary (Front) Winch	Standard	3/4	19	18x19 rotation resistant – right regular lay (Type RB)	12,920	5 860.5
	Optional	3/4	19	34x7 rotation resistant – right regular lay (Type ZB)	15,600	7 076.2

2M Main and Optional Auxiliary Winches

- Axial piston, full and half displacement (2–speed) motors driven through planetary reduction unit for positive control under all load conditions.
- Combined winch mode merges the hydraulic flow of two pumps for high–speed operation for either the main or auxiliary winch.
- Grooved lagging
- Power up/down mode of operation
- Hoist drum cable follower
- Drum rotation indicator
- Drum diameter: 16 in (40.6cm)
- Rope length:
 - Main: 670 ft (204.2m)
 - Auxiliary: 670 ft (204.2m)
- Maximum rope storage: 834 ft (254.2m)
- Terminator style socket and wedge

■ Hydraulic System

Counterbalance Valves – All hoist motors, boom extend cylinders, and boom hoist cylinders are equipped with counterbalance valves to provide load lowering and prevents accidental load drop when hydraulic power is suddenly reduced.

■ Counterweight

Standard – Total of 15,000 lb (6 803.9kg) of total counterweight consisting of one, removable 15,000 lb (6 803.9kg) counterweight with capacities for 0 lb (0kg) and 15,000 lb (6 803.9kg) counterweight configurations.

Optional – Hydraulic counterweight removal controlled from the left side of the upper structure.

Carrier

General

- 10 ft 10.5 in (3.31m) wide
- 12 ft 7 in (3.83m) wheelbase (centerline of first axle to centerline of second axle).

Frame – Box–type, torsion resistant, welded construction made of high tensile steel. Equipped with front and rear towing and tie–down lugs, tow connections, and access ladders.

Outriggers

Boxes – Two double box, front and rear welded to carrier frame.

Beams and Jacks – Four single stage beams with Confined Area Lifting Capacities (CALC™) provide selectable outrigger extensions of full, intermediate, and retracted. Hydraulically controlled from the operator's cab with integral check valves.

Pontoons – Four lightweight, quick release, 23.50 x 27.25 in (59.69 x 69.22cm), hexagonal steel pontoons with contact area of 485 in² (3 129cm²) can be stored for road travel in storage racks on the carrier.

Main Jack Reaction – 94,800 lb (43 000.6kg) force and 196 psi (1 351.4kPa) ground bearing pressure.

Steering and Axles

Steering – Three independent modes consisting of two wheel front, four wheel, and crab. Each mode is controlled from the steering wheel and is selected by a switch in the operator's cab.

Drive – Two modes: 4 x 2 and 4 x 4 for off highway travel

Axle 1 – Steered, non–driven for 4 x 2 and steered, driven for 4 x 4

Axle 2 – Steered, driven

Suspension

Front – Rigid mount to the carrier frame

Rear – Center pin mount that pivots within bronze bushings. Two hydraulic oscillation cylinders lockout when the upper structure rotates 2.5° past centerline.

Tires and Wheels

Front and Rear – Four (single) 29.5 x 25–28 ply rating, earthmover type tires on steel disc wheels

- Spare tires and wheels – optional

Brakes

Service – Full hydraulic, dual circuit, disc type brakes on all wheel ends

Parking/Emergency – Spring loaded type, acting on front axle

Electrical

Three batteries provide 12 volt operation and starting

Lights

- Front lighting includes two main headlights, and two parking/directional indicators.
- Side lighting includes two parking/directional indicators per side.
- Rear lighting includes two parking/directional indicators, two parking/brake lights, and two reversing lights.
- Other equipment includes hazard/warning system, cab light, instrument panel light, and signal horn.

Engine

Specification	CAT C6.6
Numbers of Cylinders	6
Cycle	4
Bore and Stroke: inch (mm)	4.13 x 5.00 (105 x 127)
Piston Displacement: in ³ (L)	403 (6.6)
Max. Brake Horsepower: hp (kW)	235 (175.2) @ 2,000 rpm
Peak Torque: ft lb (J)	727 (986) @ 1,400 rpm
Alternator: volts – amps	12 – 150
Crankcase Capacity: qt (L)	18.4 (17.4)
• Mechanically driven fan and thermostatically controlled radiator	

Transmission

Powershift – Three speed with high/low range for 6 forward and 6 reverse gears. Transmission oil cooler is equipped with a thermostatically controlled electric fan.

Carrier Speeds and Gradeability

Spicer		Speed		Gradeability (@ 70% Convertor efficiency)	
Gear	Ratio	mph	km/h	% Grade	
3rd	High Range	0.820	24.2	38.9	2.9
2nd		2.250	8.8	14.2	11.6
1st		4.673	4.3	6.9	26.9
3rd	Low Range	2.400	8.3	13.4	12.5
2nd		6.540	3.0	4.8	40.1
1st		13.599	1.5	2.4	131.2

Based on a gross vehicle weight of 102,000 lb (46 266.4kg).
Crane operating angle must not exceed 35° (77% grade).

Fuel Tank

One 95 gallon (359.6L) capacity tank

Hydraulic System

All functions are hydraulically powered allowing positive precise, control with independent or simultaneous operation of all functions.

Main Pumps

- Four fixed displacement gear pumps for the main and auxiliary winches, swing, boom hoist, and telescope circuits with a manual disconnect to aid during cold weather starts.
- One gear pump for the outriggers, power steering, and telescope circuits.
- One pressure compensated piston pump is used in the control, service brake, and counterweight removal circuits.
- Combined pump capacity of 167.3 gpm (633.3Lpm).

Hydraulic Reservoir – 160 gal (605.7L) capacity equipped with sight level gauge. Diffusers built in for deaeration.

Filtration – One 10 micron, full flow, line filter in the control circuit. All oil is filtered prior to return to sump tank. Accessible for easy filter replacement.

Pump Drive

All pumps are mechanically driven by the diesel engine. Main and auxiliary winches, swing, boom hoist, and telescope pumps are mounted to a mechanical pump disconnect on the transmission torque convertor to aid in cold weather starting.

Axle Loads

Base crane with full tank of fuel and 15,000 lb (6 803.9kg) counterweight	Gross Vehicle Weight ⁽¹⁾		Upper Facing Front				Upper Facing Rear			
			Front Axles		Rear Axles		Front Axles		Rear Axles	
	lb	kg	lb	kg	lb	kg	lb	kg	lb	kg
	94,449	42 841	44,068	19 989	50,381	22 852	40,232	18 249	54,217	24 592
Remove 29.5 x 25 tires and wheels	-6,732	-3 054	-3,366	-1 527	-3,366	-1 527	-3,366	-1 527	-3,366	-1 527
29.5R25 XHA tires	964	438	482	219	482	219	482	219	482	219
Remove outrigger beams	-5,235	-2 374	-2,461	-1 116	-2,774	-1 258	-2,461	-1 116	-2,774	-1 258
Jack cylinder beam covers	154	70	72	33	82	27	72	33	82	37
Tow winch	686	311	1,002	454	-316	-143	1,002	454	-316	-143
Remove 100 gal (378.5L) fuel	-685	-310	-364	-165	-321	-145	-364	-165	-321	-145
2M auxiliary winch with 670 ft (204m) of 3/4 in (19mm) wire rope	823	373	-219	-99	1,043	473	977	443	-154	-70
Remove front carrier counterweights	-1,000	-454	-1,306	-592	306	139	-1,306	-592	306	139
Hydraulic counterweight removal	353	160	163	74	190	86	518	235	-165	-75
Remove counterweight	-15,000	-6 804	8,223	3 734	-23,233	-10 538	-22,041	-9 998	7,041	3 194
Air conditioning	287	130	55	25	232	105	209	95	78	35
39.5 ft (12.04m) offsettable lattice fly – stowed	1,602	727	2,780	1 261	-1,178	-534	-1,305	-592	2,907	1 319
39.5–67 ft (12.04–20.42m) offsettable lattice fly – stowed	2,380	1 080	3,649	1 655	-1,269	-576	-1,458	-661	3,838	1 741
Fly storage brackets with all fly options	160	73	268	122	-108	-49	-120	-54	280	127
Auxiliary lifting sheave assembly	110	50	361	164	-251	-114	-260	-118	370	168
8.5 ton (7.7mt) hook ball at front bumper	360	163	566	256	-206	-93	---	---	---	---
70 ton (63.5mt) 5–sheave hook block at front bumper	1,390	631	2,186	992	-796	-361	---	---	---	---
60 ton (54.4mt) 4–sheave hook block at front bumper	1,150	522	1,809	821	-659	-299	---	---	---	---

Tire	Maximum Load @ 20 mph (32.2km/h)
29.5 x 25 (28–PR)	53,000 lb (24 041kg)
29.5R25 XHA 1 Star	53,000 lb (24 041kg)

⁽¹⁾ Adjust gross vehicle weight and axle loading according to component weight.

Note: All weights are $\pm 3\%$.

General Dimensions

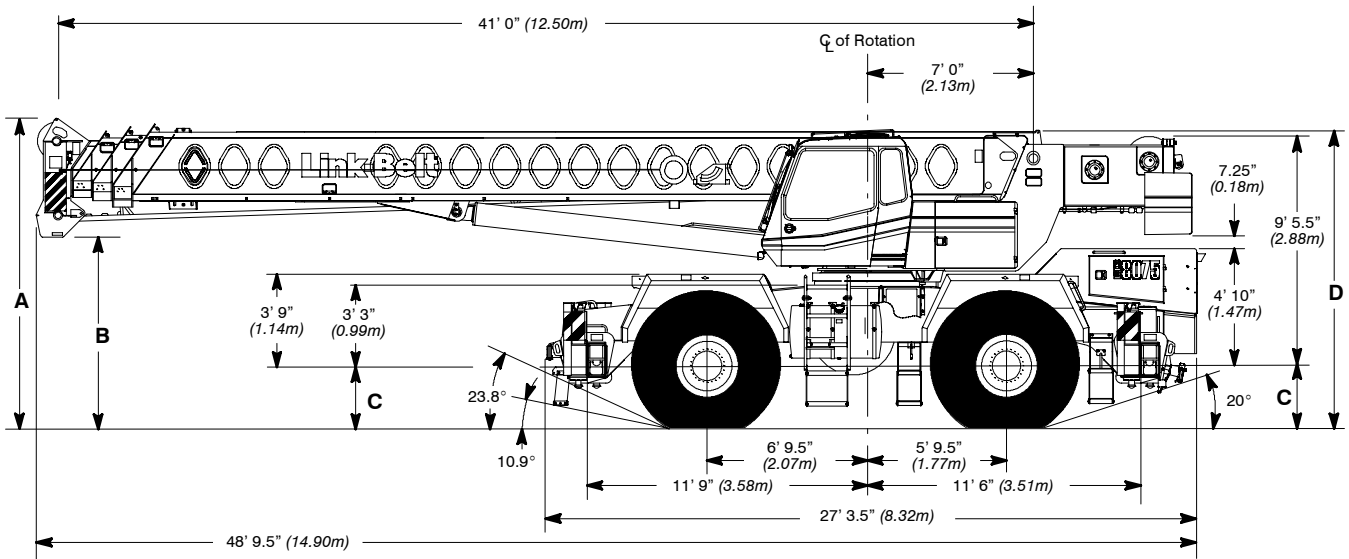

Turning Radius – Front Wheel (4x2) Steering		English	Metric
Wall to wall over carrier		49' 10"	15.2m
Wall to wall over boom		58' 3"	17.7m
Wall to wall over boom attachment		60' 2"	18.3m
Curb to curb		48' 3"	14.7m
Centerline of tire		46' 10"	14.3m

Turning Radius – All Wheel (4x4) Steering		English	Metric
Wall to wall over carrier		27' 5"	8.4m
Wall to wall over boom		39' 6"	12.1m
Wall to wall over boom attachment		41' 0"	12.5m
Curb to curb		25' 4"	7.7m
Centerline of tire		23' 10"	7.3m

Tail Swing		English	Metric
With counterweight		13' 9"	4.2m
Without counterweight		13' 1"	4.0m

General Dimensions	Tire Size			
	29.5 x 25		29.5R25	
	English	Metric	English	Metric
A	12' 10.75"	3.93m	12' 11.75"	3.97m
B	7' 11.5"	2.42m	8' 0.5"	2.44m
C	2' 8"	0.81m	2' 9"	0.84m
D	12' 5"	3.78m	12' 6"	3.81m
E	8.25"	0.21m	7' 0"	0.18m
F	25.25"	0.64m	25.25"	0.64m
G	11.25"	0.29m	12.25"	0.31m

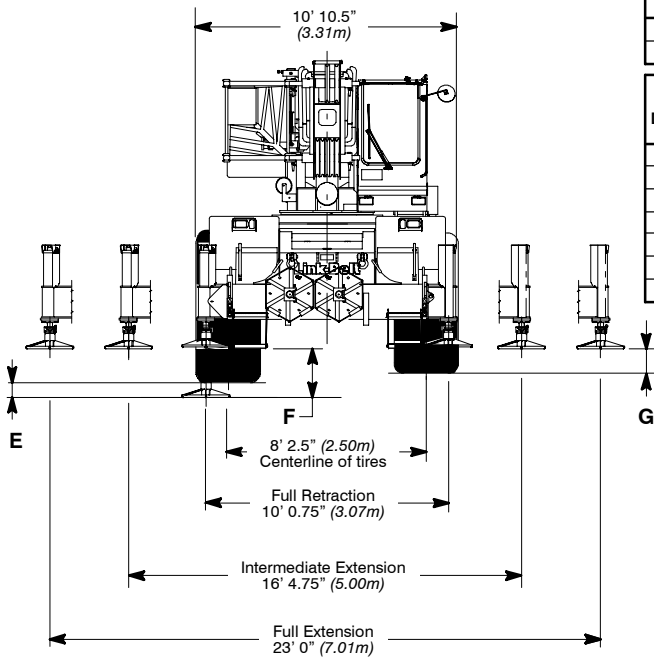

Not To Scale

Working Range Diagram

Working Range Diagram
On Fully Extended Outriggers

15,000 lb (6 804kg)
Counterweight

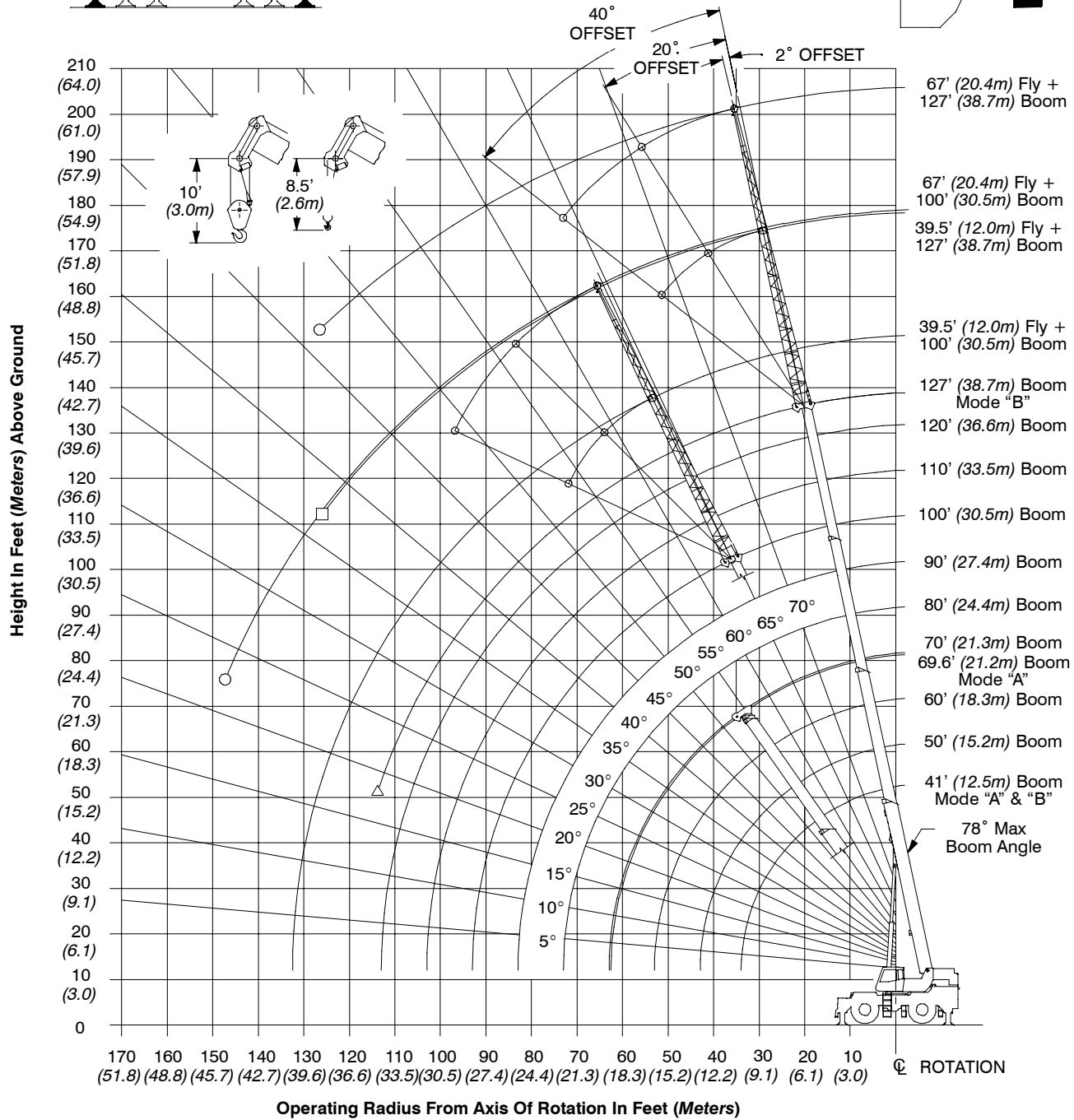
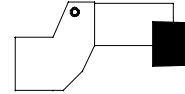

- Denotes Main Boom + 67' (20.4m) Fly – Boom Mode "B"
- Denotes Main Boom + 39.5' (12.0m) Fly – Boom Mode "B"
- △ Denotes Main Boom – Boom Mode "B"

Boom Extend Modes

Boom Mode “A” (A-max)

Only inner mid section telescopes.

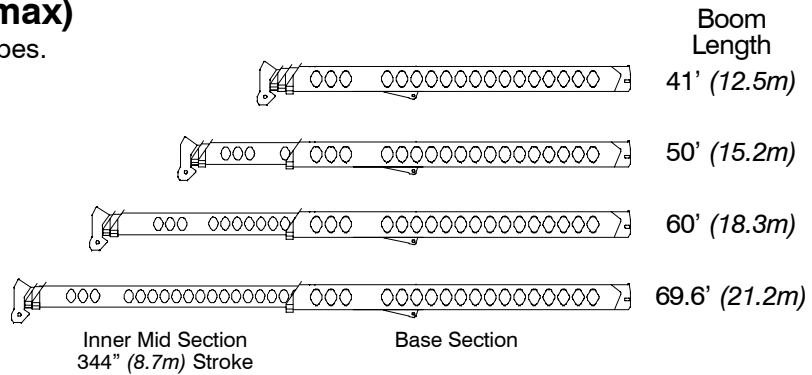

Boom Mode “B” (Standard)

Inner mid, outer mid, and tip sections telescope simultaneously.

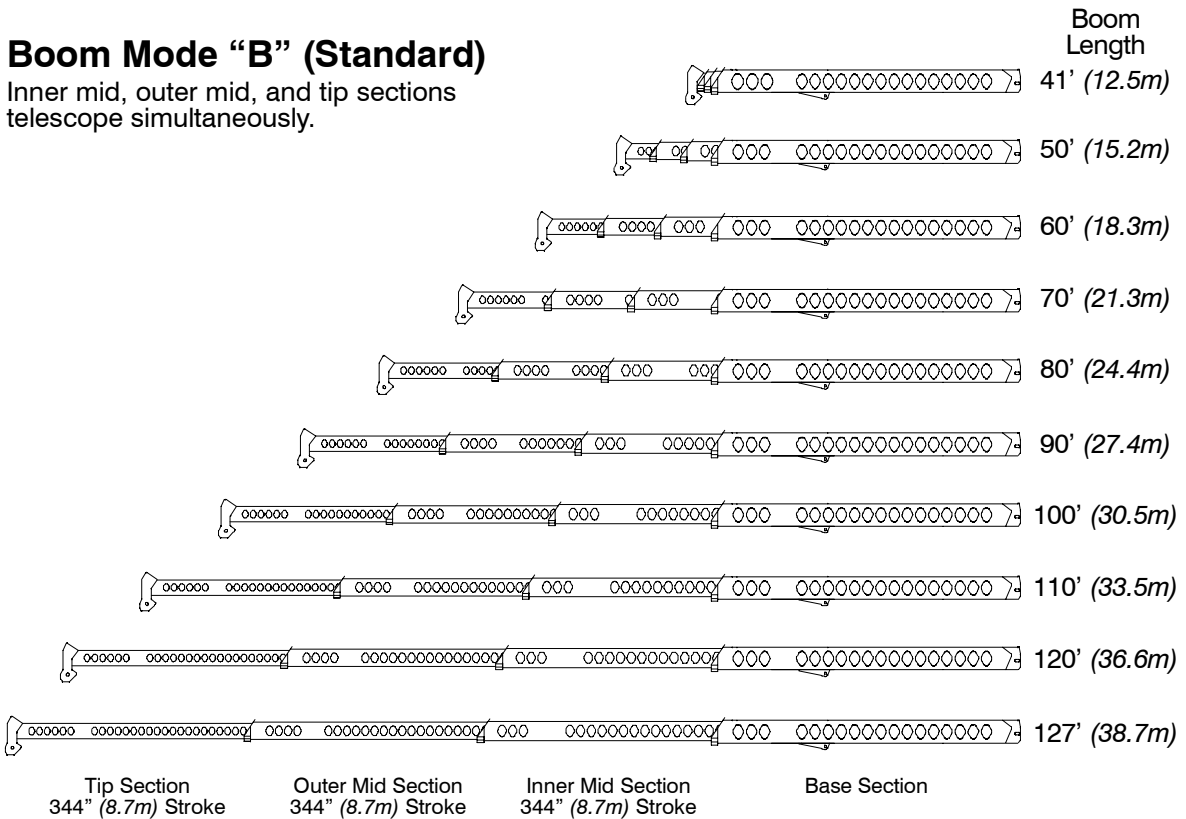

Main Boom Lift Capacity Charts – Standard

15,000 lb Counterweight – Fully Extended Outriggers – 360° Rotation (All Capacities Are Listed In Pounds)											
Radius (ft)	Boom Length (ft)										Radius (ft)
	41	50	60	69.6/70	80	90	100	110	120	127	
8	150,000*										8
9	140,000*										9
10	128,600	75,100	74,000								10
12	116,500	75,100	74,000								12
15	100,100	75,100	74,000	43,900**	38,000						15
20	74,700	74,100	73,600	43,900**	38,000	38,000	37,400				20
25	57,600	57,000	56,600	43,900**	38,000	38,000	32,700	29,400	23,300	19,600	25
30	45,900	45,500	45,100	43,900**	38,000	37,900	29,000	26,200	23,300	19,600	30
35		36,800	37,300	38,000	37,900	33,900	26,000	23,500	21,500	19,600	35
40		28,700	29,200	37,700	29,700	29,900	23,400	21,200	19,400	18,400	40
45			23,600	29,500	24,100	24,300	21,200	19,200	17,600	16,400	45
50			19,300	23,900	19,900	20,000	19,300	17,400	15,800	14,900	50
55				19,700	16,600	16,800	16,900	15,800	14,400	13,600	55
60				16,400	14,000	14,200	14,300	14,400	13,200	12,500	60
65				13,800	12,000	12,100	12,300	12,400	12,200	11,500	65
70					10,200	10,400	10,500	10,600	10,700	10,600	70
75						8,900	9,000	9,100	9,200	9,200	75
80						7,600	7,800	7,900	7,900	8,000	80
85							6,700	6,800	6,800	6,900	85
90							5,700	5,800	5,900	5,900	90
95								5,000	5,100	5,100	95
100								4,200	4,300	4,400	100
105									3,600	3,700	105
110									3,000	3,100	110
115										2,600	115

* Special Conditions Or Wire Rope Required
** 69.6 A – max Mode

This information is not for crane operation. Operator must refer to the in-cab information for crane operation. Rated lifting capacities shown on fully extended outriggers do not exceed 85% of the tipping loads and on tires do not exceed 75% of the tipping loads.

15,000 lb Counterweight – On Tires – Stationary – Boom Centered Over Front Between Tire Tracks
(All Capacities Are Listed In Pounds)

Radius (ft)	Boom Length (ft)						Radius (ft)
	41	50	60	70	80	90	
15	54,900						15
20	42,500	42,000					20
25	29,200	29,900	30,300	30,600			25
30	20,800	21,700	22,100	22,400	22,600		30
35		16,300	16,800	17,100	17,300	17,400	35
40		12,500	13,000	13,400	13,500	13,600	40
45			10,200	10,600	10,900	11,000	45
50			8,100	8,400	8,700	8,900	50
55				6,700	7,000	7,200	55
60				5,300	5,600	5,800	60
65					4,400	4,600	65
70					3,400	3,600	70

15,000 lb Counterweight – On Tires – Pick & Carry (1 mph) – Boom Centered Over Front
(All Capacities Are Listed In Pounds)

Radius (ft)	Boom Length (ft)						Radius (ft)
	41	50	60	70	80	90	
15	51,400						15
20	39,100	38,700					20
25	29,200	29,900	30,300	30,600			25
30	20,800	21,700	22,100	22,400	22,600		30
35		16,300	16,800	17,100	17,300	17,400	35
40		12,500	13,000	13,400	13,500	13,600	40
45			10,200	10,600	10,900	11,000	45
50			8,100	8,400	8,700	8,900	50
55				6,700	7,000	7,200	55
60				5,300	5,600	5,800	60
65					4,400	4,600	65
70					3,400	3,600	70

15,000 lb Counterweight – On Tires – Stationary – 360° Rotation
(All Capacities Are Listed In Pounds)

Radius (ft)	Boom Length (ft)						Radius (ft)
	41	50	60	70	80	90	
15	33,500	34,100					15
20	20,500	21,300					20
25	13,500	14,200	14,700	15,000			25
30	9,100	9,900	10,400	10,800	10,900		30
35		6,900	7,400	7,800	8,000	8,100	35
40		4,700	5,200	5,600	5,800	6,000	40
45			3,600	3,900	4,200	4,300	45
50					2,900	3,000	50

This information is not for crane operation. Operator must refer to the in-cab information for crane operation. Rated lifting capacities shown on fully extended outriggers do not exceed 85% of the tipping loads and on tires do not exceed 75% of the tipping loads.

Fly Attachment Lift Capacity Charts – Optional

15,000 lb Counterweight – Fully Extended Outriggers – 360° Rotation (All Capacities Are Listed In Pounds)								
127 ft Main Boom Length 2° Fly Offset			127 ft Main Boom Length 20° Fly Offset			127 ft Main Boom Length 40° Fly Offset		
Radius (ft)	Fly Length (ft)		Radius (ft)	Fly Length (ft)		Radius (ft)	Fly Length (ft)	
	39.5	67		39.5	67		39.5	67
35	8,300		50	8,200		65	6,200	
40	8,300		55	8,000		70	6,100	
45	8,300		60	7,800		75	6,000	
50	8,300	5,500	65	7,600		80	5,800	
55	8,300	5,500	70	7,400	4,200	85	5,700	
60	8,300	5,500	75	7,200	4,000	90	5,700	2,900
65	8,300	5,500	80	7,000	3,900	95	5,600	2,800
70	8,300	5,500	85	6,800	3,800	100	5,500	2,800
75	7,800	5,300	90	6,300	3,600	105	5,100	2,700
80	7,100	5,100	95	5,800	3,500	110	4,700	2,600
85	6,600	4,900	100	5,300	3,400	115	4,300	2,600
90	6,000	4,800	105	4,900	3,300	120	3,800	2,600
95	5,600	4,600	110	4,500	3,200	125	3,200	2,500
100	5,100	4,300	115	4,000	3,100	130	2,700	2,500
105	4,700	3,900	120	3,500	3,000	135	2,200	2,500
110	4,100	3,600	125	3,000	2,900	140		2,300
115	3,500	3,200	130	2,500	2,600	145		2,000
120	3,000	2,900	135	2,100	2,300	150		1,800
125	2,600	2,700	140		2,100	155		1,600
130	2,100	2,400	145		1,900			
135		2,200	150		1,700			

This information is not for crane operation. Operator must refer to the in-cab information for crane operation. Rated lifting capacities shown on fully extended outriggers do not exceed 85% of the tipping loads and on tires do not exceed 75% of the tipping loads.

Main Boom Lift Capacity Charts – Optional (Metric)

6 804kg Counterweight – Fully Extended Outriggers – 360° Rotation
(All Capacities Are Listed In Kilograms)

Radius (m)	Boom Length (m)										Radius (m)	
	12.5	15.2	18.3	21.21/21.3	24.4	27.4	30.5	33.5	36.6	38.71		
2.44	68 000*											2.44
2.74	63 500*											2.74
3.0	58 350	34 050	33 550									3.0
3.5	54 350	34 050	33 550	19 900**								3.5
4.0	49 850	34 050	33 550	19 900**								4.0
4.5	45 950	34 050	33 550	19 900**	17 200							4.5
5.0	42 000	34 050	33 550	19 900**	17 200							5.0
6.0	34 450	34 050	33 550	19 900**	17 200	17 200	17 150					6.0
7.0	28 900	28 650	28 450	19 900**	17 200	17 200	15 700					7.0
8.0	24 600	24 350	24 150	19 150**	17 200	17 200	14 350	12 950	10 550	8 900		8.0
9.0	19 950	19 600	19 300	17 400**	17 200	17 200	13 300	12 000	10 550	8 900		9.0
10.0	16 250	16 600	16 850	16 950	17 050	16 100	12 350	11 150	10 200	8 900		10.0
12.0		11 800	12 000	12 150	12 250	12 300	10 750	9 700	8 900	8 450		12.0
14.0			9 050	9 200	9 300	9 350	9 400	8 550	7 800	7 300		14.0
16.0			7 000	7 150	7 250	7 300	7 350	7 400	6 850	6 450		16.0
18.0				5 700	5 800	5 850	5 900	5 900	5 950	5 750		18.0
20.0					4 700	4 750	4 800	4 850	4 850	4 900		20.0
22.0					3 800	3 900	3 950	3 950	4 000	4 000		22.0
24.0						3 150	3 200	3 250	3 300	3 300		24.0
26.0							2 650	2 700	2 700	2 700		26.0
28.0							2 150	2 200	2 200	2 250		28.0
30.0								1 750	1 800	1 800		30.0
32.0									1 450	1 450		32.0
34.0									1 150	1 150		34.0

* Special Conditions Or Wire Rope Required

** 21.21 A – max Mode

This information is not for crane operation. Operator must refer to the in-cab information for crane operation. Rated lifting capacities shown on fully extended outriggers or on tires do not exceed 75% of the tipping loads.

6 804kg Counterweight – On Tires – Stationary – Boom Centered Over Front Between Tire Tracks
(All Capacities Are Listed In Kilograms)

Radius (m)	Boom Length (m)						Radius (m)
	12.5	15.2	18.3	21.3	24.4	27.4	
4.5	25 200						4.5
5.0	23 150						5.0
6.0	17 650	17 300					6.0
7.0	13 350	13 600					7.0
8.0	10 500	10 800	10 950	11 100			8.0
9.0	8 450	8 750	8 950	9 050	9 100		9.0
10.0	6 850	7 200	7 400	7 500	7 600		10.0
12.0		5 050	5 300	5 450	5 500	5 550	12.0
14.0			3 850	4 000	4 100	4 150	14.0
16.0			2 800	2 950	3 050	3 100	16.0
18.0				2 150	2 300	2 350	18.0
20.0					1 650	1 750	20.0
22.0					1 200	1 250	22.0

6 804kg Counterweight – On Tires – Pick & Carry (1.6km/h) – Boom Centered Over Front
(All Capacities Are Listed In Kilograms)

Radius (m)	Boom Length (m)						Radius (m)
	12.5	15.2	18.3	21.3	24.4	27.4	
4.5	23 650						4.5
5.0	21 550						5.0
6.0	17 650	17 300					6.0
7.0	13 350	13 600					7.0
8.0	10 500	10 800	10 950	11 100			8.0
9.0	8 450	8 750	8 950	9 050	9 100		9.0
10.0	6 850	7 200	7 400	7 500	7 600		10.0
12.0		5 050	5 300	5 450	5 500	5 550	12.0
14.0			3 850	4 000	4 100	4 150	14.0
16.0			2 800	2 950	3 050	3 100	16.0
18.0				2 150	2 300	2 350	18.0
20.0					1 650	1 750	20.0
22.0					1 200	1 250	22.0

This information is not for crane operation. Operator must refer to the in-cab information for crane operation. Rated lifting capacities shown on fully extended outriggers or on tires do not exceed 75% of the tipping loads.

6 804kg Counterweight – On Tires – Stationary – 360° Rotation (All Capacities Are Listed In Kilograms)							
Radius (m)	Boom Length (m)						Radius (m)
	12.5	15.2	18.3	21.3	24.4	27.4	
4.5	13 500						4.5
5.0	11 350						5.0
6.0	8 250	8 550					6.0
7.0	6 250	6 550					7.0
8.0	4 800	5 100	5 300	5 400			8.0
9.0	3 700	4 000	4 200	4 350	4 400		9.0
10.0	2 850	3 150	3 350	3 500	3 600	3 650	10.0
12.0		1 950	2 150	2 300	2 400	2 450	12.0
14.0			1 300	1 450	1 500	1 600	14.0

Fly Attachment Lift Capacity Charts – Optional (Metric)

6 804kg Counterweight – Fully Extended Outriggers – 360° Rotation (All Capacities Are Listed In Kilograms)								
38.71m Main Boom Length 2° Fly Offset			38.71m Main Boom Length 20° Fly Offset			38.71m Main Boom Length 40° Fly Offset		
Radius (m)	Fly Length (m)		Radius (m)	Fly Length (m)		Radius (m)	Fly Length (m)	
	12.04	20.42		12.04	20.42		12.04	20.42
12.0	3 750		12.0			12.0		
14.0	3 750		14.0			14.0		
16.0	3 750	2 450	16.0	3 650		16.0		
18.0	3 750	2 450	18.0	3 550		18.0		
20.0	3 750	2 450	20.0	3 400		20.0	2 800	
22.0	3 700	2 450	22.0	3 300	1 850	22.0	2 750	
24.0	3 300	2 350	24.0	3 200	1 800	24.0	2 650	
26.0	2 950	2 250	26.0	3 050	1 700	26.0	2 600	
28.0	2 650	2 150	28.0	2 750	1 600	28.0	2 550	1 300
30.0	2 200	2 000	30.0	2 500	1 550	30.0	2 500	1 250
32.0	1 850	1 800	32.0	2 100	1 500	32.0	2 300	1 200
34.0	1 550	1 550	34.0	1 750	1 450	34.0	1 950	1 200
36.0	1 250	1 400	36.0	1 450	1 400	36.0	1 600	1 150
38.0	1 000	1 200	38.0	1 200	1 300	38.0	1 300	1 150
40.0		1 000	40.0	950	1 150	40.0	1 000	1 150
42.0			42.0		1 000	42.0		1 100
44.0			44.0		850	44.0		950
46.0			46.0			46.0		800

This information is not for crane operation. Operator must refer to the in-cab information for crane operation. Rated lifting capacities shown on fully extended outriggers or on tires do not exceed 75% of the tipping loads.

Link-Belt Construction Equipment Company Lexington, Kentucky www.linkbelt.com

®Link-Belt is a registered trademark. Copyright 2007. We are constantly improving our products and therefore reserve the right to change designs and specifications.