



RT875BXL

ROUGH TERRAIN
HYDRAULIC CRANE



Dimensions

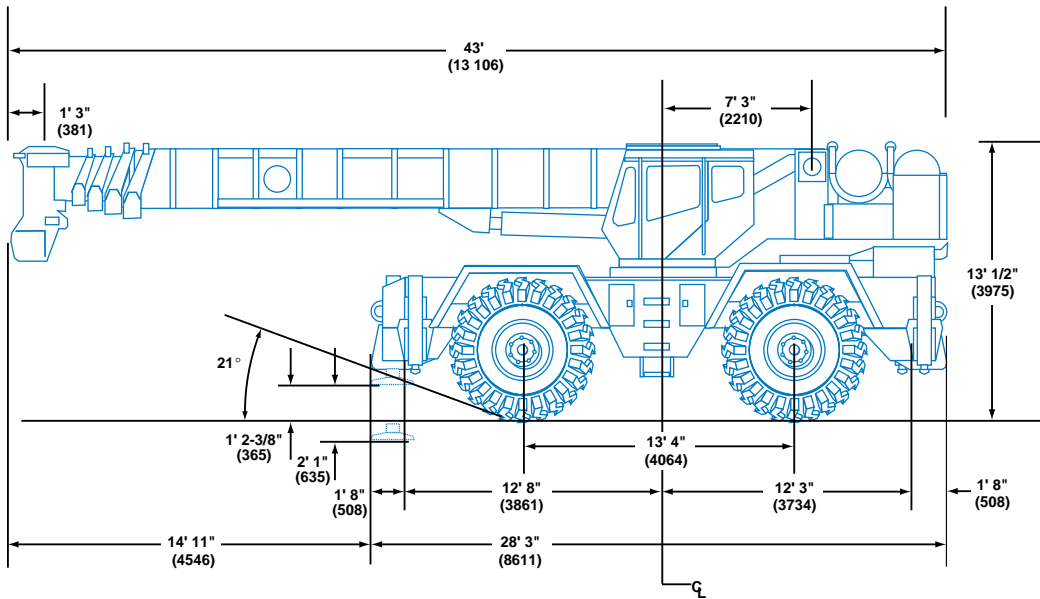
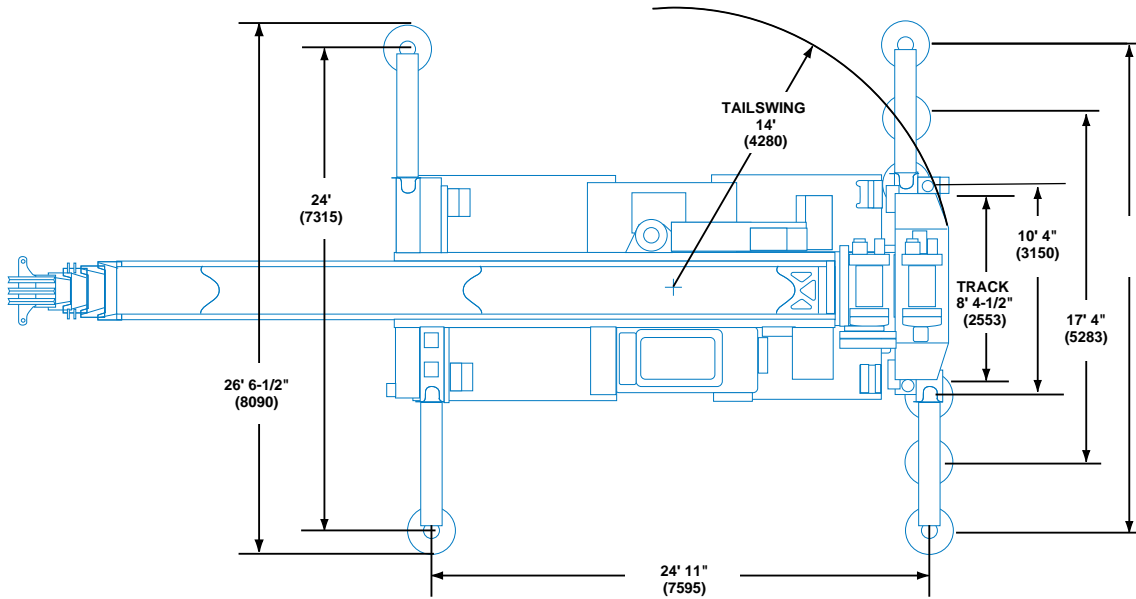

Note: () Reference dimensions in mm

Turning Radius 22' 6" (6858 mm)

Front Axle Load 51,915 lbs. (23,548 kg)

Rear Axle Load 51,556 lbs. (23,386 kg)

Gross Vehicle Weight 103,471 lbs. (46,934 kg)

Working Range

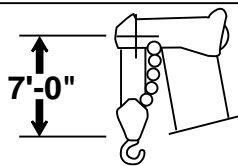
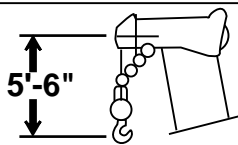
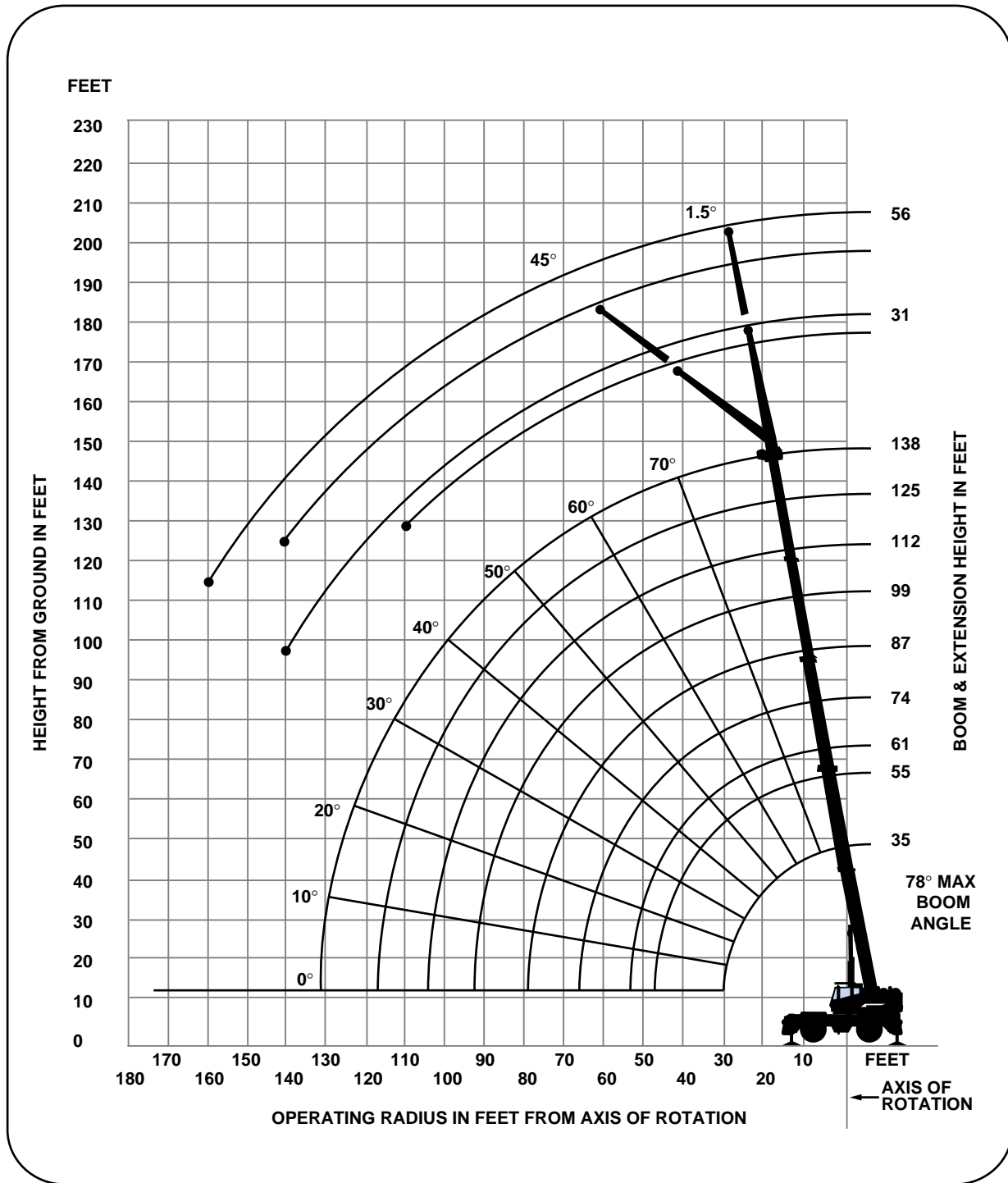

DIMENSIONS ARE FOR LARGEST GROVE FURNISHED HOOK BLOCK AND HEADACHEBALL, WITH ANTI-TWO BLOCK ACTIVATED.

Superstructure specifications

Boom

35 ft. - 138 ft. (10.6 m - 42 m) five-section full power boom.
Maximum Tip Height: 148 ft. (45.1 m).

Folding Lattice Extension

31 ft. - 56 ft. (9.4 m - 17 m) bi-fold lattice swingaway extension off-settable at 1.5° or 45° Stows alongside base section.
Maximum Tip Height: 204 ft. (62.1 m).

*Optional Lattice Extension

31 ft. (9.4 m) lattice swingaway extension. Offsettable at 1.5° or 45°. Stows alongside base boom section.
Maximum Tip Height: 179 ft. (54.5 m).

Boom Nose

Five Nylatron sheaves mounted on heavy duty tapered roller bearings with removable pin-type rope guards. Quick reeving type boom nose. A removable auxiliary boom nose with removable pin type rope guard.

Boom Elevation

One double acting hydraulic cylinder with integral holding valve provides elevation from -3° to 78°.

Load Moment & Anti-Two Block System

Standard load moment and anti-two block system with audio-visual warning and control lever lockout. These systems provide electronic display of boom angle, length, radius, tip height, relative load moment, maximum permissible load and load indication and warning of impending two-block condition.

Cab

Full vision, all galvanealed steel fabricated with acoustical lining and tinted safety glass throughout. Deluxe seat with armrest mounted hydraulic single axis controllers. Dash panel incorporates gauges for engine functions. Other standard features include: skylight screen, hydraulic oil cab heater/defroster, telescoping tilt wheel, sliding side and rear windows, opening skylight, electric windshield wash-wipe, electric skylight wipers, fire extinguisher, seat belt, ashtray and level indicator.

Swing

Planetary swing with foot applied multi-disc wet brake. Spring applied, hydraulically released swing brake, 360° positive swing lock (N.Y.C. style) and 1 position, mechanical house lock, operated from cab.
Maximum speed: 2.0 RPM.

Counterweight

Removable: 8,500 lbs. (3855 kg).
2,155 lbs. (977 kg) slab I.P.O. auxiliary hoist.

Hydraulic System

Seven main pumps with a combined capacity 199.2 GPM (754 LPM). Maximum operating pressure 3500 psi (241 bar). Three individual valve banks. Return line type filter with full flow by-pass protection and service indicator. Replaceable cartridge with micron filtration rating of 5/12/16. 200 gallons (757 L) reservoir. Remote mounted oil cooler with thermostatically controlled hydraulic motor driven fan/air to oil. System pressure test panel with quick release type fittings for each circuit.

Hoist Specifications Main and Auxiliary Hoist

Planetary reduction with automatic spring applied multi-disc brake. Electronic hoist drum rotation indicator, hoist drum cable followers and wire rope.

Maximum Single Line Pull: 16,969 lbs.
(7697 kg)

Maximum Single Line Speed: 385 FPM
(117 m/min)

Maximum Permissible
Line Pull: 12,920 lbs.
(5860 kg)

Rope Diameter: 3/4 in.
(19 mm)

Rope Length: 620 ft.
(190 m)

Maximum Rope Stowage: 1,163 ft.
(354.5 m)

Carrier specifications

Chassis

Box section frame fabricated from high-strength, low alloy steel. Integral outrigger housings and front/rear towing and tie down lugs.

Outrigger System

Four hydraulic telescoping single-stage double box beam outriggers with inverted jacks and integral holding valves. Three position setting. All steel fabricated quick release type outrigger floats, 30.5" (77.5 mm) diameter. Maximum outrigger pad load: 94,000 lbs. (42 638 kg).

Outrigger Controls

Controls and crane level indicator located in cab.

Engine

Cummins 6CTA 8.3 diesel, six cylinders, turbocharged, 250 bhp (186 kW) (Gross) @ 2,200 RPM. Maximum torque: 794 ft. lbs. (1077 Nm) @ 1,500 RPM.

*Optional Engine

Caterpillar 3126TA diesel, six cylinders, turbocharged, 250 bhp (186 kW) (Gross) @ 2,500 RPM. Maximum torque: 686 ft. lbs. (930 Nm) @ 1,650 RPM.

Fuel Tank Capacity

80 gallons (303 L)

Transmission

Full powershift with 6 forward and 6 reverse speeds. Rear axle disconnect for 4 x 2 travel.

Electrical System

Two 12 V - maintenance free batteries. 24 V starting and lighting.

Drive

4 x 4.

Steering

Fully independent power steering:

Front: Full hydraulic steering wheel controlled.

Rear: Full hydraulic hand lever controlled.

Provides infinite variations of 4 main steering modes: front only, rear only, crab and coordinated.

Rear steer indicating gauge.

Axles

Front: Drive steer with differential and planetary reduction hubs rigid mounted to frame.

Rear: Drive/steer with differential and planetary reduction hubs pivot mounted to frame.

Automatic full hydraulic lockouts on rear axle.

Oscillation Lockouts

Automatic full hydraulic lockouts on rear axle permits oscillation only with boom centered over the front.

Brakes

Full air split circuit operating on all wheels. Spring-applied, air released front and rear axles.

Tires

Std. 33.25 x 29 - 32PR earthmover type.

*Optional: 33.25R29 radial.

Lights

Full lighting including turn indicators, head, tail, brake, and hazard warning lights.

Maximum Speed

25 MPH (40 kph).

Gradeability (Theoretical)

87% based on 102,840 lbs. (46 648 kg) GVW.

33.25 x 29 tires, pumps disengaged, 138 ft. (42 m) boom, plus 31 ft. (9.4 m) swingaway.

Miscellaneous Standard Equipment

Full width steel fenders, dual rear view mirrors, hookblock tiedown, electronic back-up alarm, light package, front stowage well, tachometer/hourmeter, cold start aid (less canister), rear wheel position indicator, hydraulic cab heater, hoist mirrors, engine distress A/V warning system, tire inflation kit.

*Optional Equipment

- * **Popular Option Package** - cab controlled cross axle differential locks front and rear.
- * **Auxiliary Lighting Package** - cab mounted remote controlled worklights, cab mounted amber flashing light, hoist mounted worklight, and dual base boom mounted floodlights.
- * **Convenience Package** - includes immersion type engine block heater (120 V, 1500 watt), in-cab LMI light bar, and auto-grease system for turntable.

**Denotes optional equipment*

**RATED LIFTING CAPACITIES IN POUNDS WITH COUNTERWEIGHT
35 FT. - 138 FT. BOOM
ON OUTRIGGERS FULLY EXTENDED - 360°**

Radius in Feet	#0001								
	Main Boom Length in Feet								
	35	55	61	74	87	99	112	125	138
10	+150,000 (65.5)	79,100 (76)	78,450 (77.5)	*57,050 (80)					
12	106,500 (62)	79,100 (73.5)	77,500 (75.5)	57,050 (78.5)	*43,300 (80)				
15	90,050 (56)	79,100 (70)	69,850 (72.5)	51,650 (76)	43,300 (78.5)	*32,100 (80)			
20	68,300 (44.5)	67,350 (64.5)	59,850 (67.5)	44,350 (71.5)	39,550 (75)	32,100 (77.5)	*30,050 (80)	*20,150 (80)	
25	52,250 (29.5)	51,150 (58)	51,450 (62)	38,750 (67.5)	33,800 (71.5)	32,100 (74.5)	30,050 (77)	20,150 (79)	*19,000 (80)
30		39,200 (51)	39,450 (56.5)	34,200 (63)	29,200 (68)	30,200 (71.5)	27,350 (74.5)	19,100 (76.5)	18,300 (78.5)
35		31,000 (43.5)	31,300 (50)	29,050 (58.5)	25,800 (64)	26,600 (68.5)	24,300 (71.5)	18,100 (74)	17,650 (76.5)
40		25,050 (34.5)	25,350 (43)	25,150 (53.5)	22,900 (60)	23,450 (65)	21,600 (69)	17,250 (72)	17,000 (74)
45		20,500 (21.5)	20,800 (35)	20,600 (48.5)	20,000 (56)	20,450 (61.5)	19,250 (66)	16,450 (69)	16,350 (72)
50			17,250 (24.5)	16,850 (42.5)	16,900 (52)	17,900 (58.5)	16,900 (63)	15,750 (66.5)	15,700 (69.5)
60				10,500 (28)	10,600 (42.5)	11,800 (51)	13,000 (57)	13,100 (61.5)	13,300 (65)
70					6,500 (30)	7,670 (42.5)	8,860 (50)	10,050 (56)	11,050 (60)
80						4,710 (32)	5,910 (42.5)	7,090 (49.5)	8,290 (55)
90						2,390 (15.5)	3,690 (33.5)	4,880 (43)	6,060 (49.5)
100							1,910 (21)	3,170 (35)	4,340 (43)
110								1,810 (24.5)	2,970 (36)
120									1,860 (27)
Minimum boom angle (deg.) for indicated length (no load)								16	18
Maximum boom length (ft.) at 0 degree boom angle (no load)								112	

NOTE: () Boom angles are in degrees.

#LMI operating code. Refer to LMI manual for instructions.

*This capacity is based upon maximum boom angle.

+12 parts line required to lift this capacity (using aux. boom nose). Refer to reeving diagram.

Lifting Capacities On Outriggers Fully Extended - 360° At Zero Degree Boom Angle										
Boom Angle	Main Boom Length in Feet									
	35	55	61	74	87	99	112			
0°	27,400 (28.2)	12,850 (47.4)	10,400 (53.8)	6,290 (66.6)	3,380 (79.4)	1,970 (92.2)	1,170 (105)			

NOTE: () Reference radii in feet.

A6-829-016119A

Boom Extension Sequence in %									
Inner-Mid	0	50	50	75	100	100	100	100	100
Mid	0	25	50	75	100	100	100	100	100
Outer-Mid	0	0	0	0	0	25	50	75	100
Fly	0	0	0	0	0	25	50	75	100

31 FT. - 56 FT. FOLDING BOOM EXTENSION USING 125 FT. MAIN BOOM ON OUTRIGGERS FULLY EXTENDED - 360° WITH COUNTERWEIGHT

Radius in Feet	31 FT. LENGTH		56 FT. LENGTH	
	#0021	#0023	#0041	#0043
	1.5° OFFSET	45° OFFSET	1.5° OFFSET	45° OFFSET
30	*11,500 (80)			
35	11,500 (78.5)			
40	11,500 (77)		6,950 (79.5)	
45	11,500 (75)	*8,000 (80)	6,780 (78.5)	
50	11,000 (73.5)	6,810 (78.5)	6,620 (77)	
60	10,050 (70)	6,490 (74.5)	6,290 (74)	
70	9,220 (66)	6,400 (70.5)	5,960 (71)	*3,700 (80)
80	8,440 (62)	6,350 (66)	5,640 (67.5)	3,520 (76.5)
90	6,900 (57.5)	6,340 (61.5)	5,260 (64.5)	3,400 (72.5)
100	5,090 (53)	5,860 (56.5)	4,980 (60.5)	3,290 (68.5)
110	3,640 (47.5)	4,180 (51)	4,630 (56.5)	3,190 (64)
120	2,450 (41.5)		3,420 (52)	3,110 (59.5)
130	1,450 (34.5)		2,360 (47.5)	3,040 (54)
140			1,460 (42.5)	
Minimum boom angle (deg.) for indicated length (no load)	33	45	39	49
Maximum boom length (ft.) at 0 degree boom angle (no load)	87		74	

NOTE: () Boom angles are in degrees.

A6-829-014898A

#LMI operating code. Refer to LMI manual for instructions.

*This capacity is based upon maximum boom angle.

1. All capacities above the bold line are based on structural strength of boom extension and do not exceed 85% of tipping loads, in accordance with SAE J-765.
2. 31 ft. and 56 ft. folding boom extension lengths may be used for single line lifting service only.
3. For main boom lengths less than 125 ft. with the boom extension erected, the rated loads are determined by boom angle. Use only the column which corresponds to the boom extension length and offset for which the machine is set up. For boom angles not shown, use rating of the next lower boom angle.
4. **WARNING:** Operation of this machine with heavier loads than the capacities listed is strictly prohibited. Machine tipping with boom extension occurs rapidly and without advance warning.
5. Boom angle is the angle above or below horizontal of the longitudinal axis of the boom base section after lifting rated load.
6. Capacities listed are with outriggers properly extended and vertical jacks set only.

31 FT. - 56 FT. FOLDING BOOM EXTENSION USING 138 FT. MAIN BOOM ON OUTRIGGERS FULLY EXTENDED - 360° WITH COUNTERWEIGHT

Radius in Feet	31 FT. LENGTH		56 FT. LENGTH	
	#0021	#0023	#0041	#0043
	1.5° OFFSET	45° OFFSET	1.5° OFFSET	45° OFFSET
35	9,500 (79.5)			
40	9,500 (78)		*5,500 (80)	
45	9,500 (76.5)		5,400 (79.5)	
50	9,500 (75)	*7,800 (80)	5,300 (78)	
60	9,110 (71.5)	6,740 (77)	5,100 (75.5)	
70	8,450 (68.5)	6,460 (73.5)	4,900 (72.5)	*3,600 (80)
80	7,550 (64.5)	6,350 (69.5)	4,700 (69.5)	3,500 (77.5)
90	6,990 (60.5)	6,280 (65.5)	4,500 (66.5)	3,400 (74)
100	5,480 (56.5)	6,220 (61)	4,300 (63.5)	3,300 (70.5)
110	3,980 (52)	4,710 (56.5)	4,100 (59.5)	3,200 (67)
120	2,750 (47)	3,320 (51)	3,650 (56)	3,100 (63)
130	1,740 (41.5)		2,690 (52)	3,000 (58.5)
140			1,870 (47.5)	2,540 (53.5)
150			1,130 (42.5)	
Minimum boom angle (deg.) for indicated length (no load)	37	45	42	47
Maximum boom length (ft.) at 0 degree boom angle (no load)	87		74	

NOTE: () Boom angles are in degrees.

A6-829-014897

#LMI operating code. Refer to LMI manual for instructions.

*This capacity is based upon maximum boom angle.

1. All capacities above the bold line are based on structural strength of boom extension and do not exceed 85% of tipping loads, in accordance with SAE J-765.
2. 31 ft. and 56 ft. folding boom extension lengths may be used for single line lifting service only.
3. For main boom lengths between 125 ft. and fully extended with the boom extension erected, the rated loads are determined by boom angle. Use only the column which corresponds to the boom extension length and offset for which the machine is set up. For boom angles not shown, use rating of the next lower boom angle.
4. **WARNING:** Operation of this machine with heavier loads than the capacities listed is strictly prohibited. Machine tipping with boom extension occurs rapidly and without advance warning.
5. Boom angle is the angle above or below horizontal of the longitudinal axis of the boom base section after lifting rated load.
6. Capacities listed are with outriggers properly extended and vertical jacks set only.

RATED LIFTING CAPACITIES IN POUNDS WITH COUNTERWEIGHT 35 FT. - 138 FT. BOOM

ON OUTRIGGERS 50% EXTENDED (17' 4" SPREAD) - 360°

Radius in Feet	#4001								
	Main Boom Length in Feet								
	35	55	61	74	87	99	112	125	138
10	115,000 (65.5)	79,100 (76)	78,450 (77.5)	*57,050 (80)					
12	101,500 (62)	79,100 (73.5)	77,500 (75.5)	57,050 (78.5)	*43,300 (80)				
15	86,150 (56)	79,100 (70)	69,850 (72.5)	51,650 (76)	43,300 (78.5)	*32,100 (80)			
20	62,850 (44.5)	56,100 (64.5)	55,000 (67.5)	44,350 (71.5)	39,550 (75)	32,100 (77.5)	*30,050 (80)	*20,150 (80)	
25	39,750 (29.5)	37,950 (58)	38,300 (62)	35,950 (67.5)	33,800 (71.5)	32,100 (74.5)	30,050 (77)	20,150 (79)	*19,000 (80)
30		26,000 (51)	26,800 (56.5)	26,450 (63)	25,150 (68)	25,800 (71.5)	26,150 (74.5)	19,100 (76.5)	18,300 (78.5)
35		18,550 (43.5)	19,250 (50)	18,800 (58.5)	18,700 (64)	19,900 (68.5)	20,500 (71.5)	18,100 (74)	17,650 (76.5)
40	See Note 16	13,550 (34.5)	14,100 (43)	13,550 (53.5)	13,550 (60)	14,750 (65)	15,900 (69)	16,750 (72)	17,000 (74)
45		9,890 (21.5)	10,350 (35)	9,800 (48.5)	9,810 (56)	10,950 (61.5)	12,150 (66)	13,300 (69)	14,000 (72)
50			7,560 (24.5)	6,930 (42.5)	6,980 (52)	8,140 (58.5)	9,310 (63)	10,450 (66.5)	11,600 (69.5)
60				2,870 (28)	2,970 (42.5)	4,110 (51)	5,260 (57)	6,400 (61.5)	7,540 (65)
70						1,400 (42.5)	2,530 (50)	3,660 (56)	4,790 (60)
80								1,690 (49.5)	2,810 (55)
90									1,310 (49.5)
0.1A (lbs.)	1,270	1,340	1,310	1,330	1,350	1,230	1,140	1,070	1,010
Minimum boom angle (deg.) for indicated length (no load)				24	35	40	43	45	47
Maximum boom length (ft.) at 0° boom angle (no load)				61					

NOTE: () Boom angles are in degrees.

#LMI operating code. Refer to LMI manual for instructions.

*This capacity is based upon maximum boom angle.

Lifting Capacities On Outriggers 50% Extended - 360° At Zero Degree Boom Angle									
Boom Angle	Main Boom Length in Feet								
	35	55	61						
0°	27,400 (28.2)	8,500 (47.4)	5,850 (53.8)						

NOTE: () Reference radii in feet.

A6-829-014849A

Boom Extension Sequence in %									
Inner-Mid	0	50	50	75	100	100	100	100	100
Mid	0	25	50	75	100	100	100	100	100
Outer-Mid	0	0	0	0	0	25	50	75	100
Fly	0	0	0	0	0	25	50	75	100

**31 FT. - 56 FT. FOLDING BOOM EXTENSION USING 125 FT. MAIN BOOM
ON OUTRIGGERS 50% EXTENDED (17' 4" SPREAD) - 360° WITH COUNTERWEIGHT**

Radius in Feet	31 FT. LENGTH		56 FT. LENGTH	
	#4021	#4023	#4041	#4043
	1.5° OFFSET	45° OFFSET	1.5° OFFSET	45° OFFSET
30	*11,500 (80)			
35	11,500 (78.5)			
40	11,500 (77)		6,950 (79.5)	
45	11,500 (75)	*8,000 (80)	6,780 (78.5)	
50	11,000 (73.5)	6,810 (78.5)	6,620 (77)	
60	8,070 (70)	6,490 (74.5)	6,290 (74)	
70	5,580 (66)	6,400 (70.5)	5,960 (71)	*3,700 (80)
80	3,710 (62)	5,080 (66)	4,390 (67.5)	3,520 (76.5)
90	2,100 (57.5)	3,130 (61.5)	2,940 (64.5)	3,400 (72.5)
100		1,610 (56.5)	1,790 (60.5)	3,290 (68.5)
110				2,430 (64)
120				1,230 (59.5)
0.1A (lbs.)	990	900	910	810
Minimum boom angle (deg.) for indicated length (no load)	53	55	57	58
Maximum boom length (ft.) at 0° boom angle (no load)	61		35	

NOTE: () Boom angles are in degrees.

A6-829-014902A

#LMI operating code. Refer to LMI manual for instructions.

*This capacity is based upon maximum boom angle.

1. All capacities above the bold line are based on structural strength of boom extension. Capacities correspond to SAE J1289 (Test Load = 1.25P + 0.1A). 0.1A represents one-tenth (0.10) of the total boom weight reduced to the boom point.
2. 31 ft. and 56 ft. folding boom extension lengths may be used for single line lifting service only.
3. For main boom lengths less than 125 ft. with the boom extension erected, the rated loads are determined by boom angle. Use only the column which corresponds to the boom extension length and offset for which the machine is set up. For boom angles not shown, use rating of the next lower boom angle.
4. **WARNING:** Operation of this machine with heavier loads than the capacities listed is strictly prohibited. Machine tipping with boom extension occurs rapidly and without advance warning.
5. Boom angle is the angle above or below horizontal of the longitudinal axis of the boom base section after lifting rated load.
6. Capacities listed are with outriggers properly extended and vertical jacks set only.

**31 FT. - 56 FT. FOLDING BOOM EXTENSION USING 138 FT. MAIN BOOM
ON OUTRIGGERS 50% EXTENDED (17' 4" SPREAD) - 360° WITH COUNTERWEIGHT**

Radius in Feet	31 FT. LENGTH		56 FT. LENGTH	
	#4021	#4023	#4041	#4043
	1.5° OFFSET	45° OFFSET	1.5° OFFSET	45° OFFSET
35	9,500 (79.5)			
40	9,500 (78)		*5,500 (80)	
45	9,500 (76.5)		5,400 (79.5)	
50	9,500 (75)	*7,800 (80)	5,300 (78)	
60	8,220 (71.5)	6,740 (77)	5,100 (75.5)	
70	5,760 (68.5)	6,460 (73.5)	4,900 (72.5)	*3,600 (80)
80	3,920 (64.5)	5,450 (69.5)	4,460 (69.5)	3,500 (77.5)
90	2,480 (60.5)	3,690 (65.5)	3,030 (66.5)	3,400 (74)
100	1,220 (56.5)	2,140 (61)	1,890 (63.5)	3,300 (70.5)
110				2,280 (67)
120				1,230 (63)
0.1A (lbs.)	960	880	900	810
Minimum boom angle (deg.) for indicated length (no load)	53	57	59	61
Maximum boom length (ft.) at 0° boom angle (no load)	61		35	

NOTE: () Boom angles are in degrees.

A6-829-014901B

#LMI operating code. Refer to LMI manual for instructions.

*This capacity is based upon maximum boom angle.

1. All capacities above the bold line are based on structural strength of boom extension. Capacities correspond to SAE J1289 (Test Load = 1.25P + 0.1A). 0.1A represents one-tenth (0.10) of the total boom weight reduced to the boom point.
2. 31 ft. and 56 ft. folding boom extension lengths may be used for single line lifting service only.
3. For main boom lengths between 125 ft. and fully extended with the boom extension erected, the rated loads are determined by boom angle. Use only the column which corresponds to the boom extension length and offset for which the machine is set up. For boom angles not shown, use rating of the next lower boom angle.
4. **WARNING:** Operation of this machine with heavier loads than the capacities listed is strictly prohibited. Machine tipping with boom extension occurs rapidly and without advance warning.
5. Boom angle is the angle above or below horizontal of the longitudinal axis of the boom base section after lifting rated load.
6. Capacities listed are with outriggers properly extended and vertical jacks set only.

RATED LIFTING CAPACITIES IN POUNDS WITH COUNTERWEIGHT 35 FT. - 138 FT. BOOM

ON OUTRIGGERS 0% EXTENDED (10' 4" SPREAD) - 360°

Radius in Feet	#8001								
	Main Boom Length in Feet								
	35	55	61	74	87	99	112	125	138
10	86,700 (65.5)	71,750 (76)	69,000 (77.5)	*57,050 (80)					
12	65,550 (62)	55,400 (73.5)	53,700 (75.5)	49,100 (78.5)	*43,300 (80)				
15	46,750 (56)	40,050 (70)	39,200 (72.5)	36,150 (76)	33,550 (78.5)	*32,100 (80)			
20	29,400 (44.5)	25,650 (64.5)	25,350 (67.5)	23,500 (71.5)	21,950 (75)	22,400 (77.5)	*22,550 (80)	*20,150 (80)	
25	19,100 (29.5)	17,450 (58)	17,400 (62)	16,050 (67.5)	14,950 (71.5)	15,750 (74.5)	16,200 (77)	16,450 (79)	*16,550 (80)
30		11,450 (51)	12,150 (56.5)	11,150 (63)	10,300 (68)	11,250 (71.5)	11,850 (74.5)	12,250 (76.5)	12,500 (78.5)
35		7,350 (43.5)	7,950 (50)	7,540 (58.5)	6,980 (64)	8,020 (68.5)	8,730 (71.5)	9,230 (74)	9,580 (76.5)
40	See Note 16	4,420 (34.5)	4,940 (43)	4,460 (53.5)	4,430 (60)	5,570 (65)	6,350 (69)	6,910 (72)	7,320 (74)
45		2,240 (21.5)	2,690 (35)	2,150 (48.5)	2,160 (56)	3,290 (61.5)	4,410 (66)	5,080 (69)	5,530 (72)
50						1,500 (58.5)	2,590 (63)	3,600 (66.5)	4,080 (69.5)
60									1,880 (65)
0.1A (lbs.)	1,270	1,340	1,310	1,330	1,350	1,230	1,140	1,070	1,010
Minimum boom angle (deg.) for indicated length (no load)			25	44	53	56	59	62	62
Maximum boom length (ft.) at 0 degree boom angle (no load)			55						

NOTE: () Boom angles are in degrees.

#LMI operating code. Refer to LMI manual for instructions.

*This capacity is based upon maximum boom angle.

Lifting Capacities On Outriggers 0% Extended - 360° At Zero Degree Boom Angle									
Boom Angle	Main Boom Length in Feet								
	35	55							
0°	14,950 (28.2)	1,390 (47.4)							

NOTE: () Reference radii in feet.

A6-829-014851A

Boom Extension Sequence in %									
Inner-Mid	0	50	50	75	100	100	100	100	100
Mid	0	25	50	75	100	100	100	100	100
Outer-Mid	0	0	0	0	0	25	50	75	100
Fly	0	0	0	0	0	25	50	75	100

RATED LIFTING CAPACITIES ON RUBBER WITH COUNTERWEIGHT 33.25x29 GENERAL TIRES

STATIONARY CAPACITIES - 360°

Radius in Feet	#9005				
	Main Boom Length in Feet				
	35	55	61	74	87
10	45,200 (65.5)	40,850 (76)			
12	43,100 (62)	40,850 (73.5)			
15	29,400 (56)	29,400 (70)	29,400 (72.5)	29,400 (76)	
20	17,750 (44.5)	17,750 (64.5)	17,750 (67.5)	17,750 (71.5)	17,750 (75)
25	11,300 (29.5)	11,300 (58)	11,300 (62)	11,300 (67.5)	11,300 (71.5)
30		7,300 (51)	7,300 (56.5)	7,300 (63)	7,300 (68)
35		4,520 (43.5)	4,520 (50)	4,520 (58.5)	4,520 (64)
40		2,290 (34.5)	2,290 (43)	2,290 (53.5)	2,290 (60)
Minimum boom angle (deg.) for indicated length (no load)		31	40	50	58
Maximum boom length (ft.) at 0 degree boom angle (no load)		35			

NOTE: () Boom angles are in degrees.

#LMI operating code. Refer to LMI manual for operating instructions.

Capacities at Zero Degree Boom Angle					
Boom Angle	Main Boom Length in Feet				
	35				
0°	9,350 (28.2)				

NOTE: () Reference radii in feet.

A6-829-015116

1. Capacities do not exceed 75% of tipping loads as determined by test in accordance with SAE J765.
2. Capacities are applicable to machines equipped with 33.25x29 (32 ply) General tires at 65 psi cold inflation pressure.
3. Defined Arc - Over front includes 6° on either side of longitudinal centerline of machine.
4. Capacities appearing above the bold line are based on structural strength and tipping should not be relied upon as a capacity limitation.
5. Capacities are applicable only with machine on firm level surface.
6. On rubber lifting with boom extensions not permitted.
7. For pick and carry operation, boom must be centered over front of machine, mechanical swing lock engaged and load restrained from swinging. When handling loads in the structural range with capacities close to maximum ratings, travel should be reduced to creep speeds.
8. Axle lockouts must be functioning when lifting on rubber.
9. All lifting depends on proper tire inflation, capacity and condition. Capacities must be reduced for lower tire inflation pressures. See lifting capacity chart for tire used. Damaged tires are hazardous to safe operation of crane.
10. Creep - not over 200 ft. of movement in any 30 minute period and not exceeding 1 mph.

RATED LIFTING CAPACITIES ON RUBBER (cont'd.)

PICK & CARRY CAPACITIES - UP TO 2.5 MPH
BOOM CENTERED OVER FRONT (SEE NOTE 7)

Radius in Feet	#9006				
	Main Boom Length in Feet				
	35	55	61	74	87
10	45,200 (65.5)	29,150 (76)			
12	45,200 (62)	29,150 (73.5)			
15	37,250 (56)	29,150 (70)	26,900 (72.5)	18,150 (76)	
20	30,600 (44.5)	29,150 (64.5)	26,900 (67.5)	18,150 (71.5)	12,400 (75)
25	20,250 (29.5)	20,250 (58)	20,250 (62)	18,150 (67.5)	12,400 (71.5)
30		14,400 (51)	14,400 (56.5)	14,440 (63)	12,400 (68)
35		10,650 (43.5)	10,650 (50)	10,650 (58.5)	10,650 (64)
40		7,940 (34.5)	7,940 (43)	7,940 (53.5)	7,940 (60)
45		5,920 (21.5)	5,920 (35)	5,920 (48.5)	5,920 (56)
50			4,380 (24.5)	4,380 (42.5)	4,380 (52)
60				2,160 (28)	2,160 (42.5)
Minimum boom angle (deg.) for indicated length (no load)					40
Maximum boom length (ft.) at 0 degree boom angle (no load)					74

NOTE: () Boom angles are in degrees.

#LMI operating code. Refer to LMI manual for operating instructions.

Capacities at Zero Degree Boom Angle					
Boom Angle	Main Boom Length in Feet				
	35	55	61	74	
0°	16,500 (28.2)	5,140 (47.4)	3,430 (53.8)	1,110 (66.6)	

NOTE: () Reference radii in feet.

A6-829-015118

RATED LIFTING CAPACITIES ON RUBBER WITH COUNTERWEIGHT 33.25Rx29 GENERAL TIRES

STATIONARY CAPACITIES DEFINED ARC OVER FRONT (SEE NOTE 3)

Radius in Feet	#9005				
	Main Boom Length in Feet				
	35	55	61	74	87
10	45,200 (65.5)	40,850 (76)			
12	45,200 (62)	40,850 (73.5)	40,850 (75.5)		
15	45,200 (56)	40,850 (70)	40,850 (72.5)	34,400 (76)	
20	40,850 (44.5)	40,850 (64.5)	40,850 (67.5)	34,400 (71.5)	24,050 (75)
25	27,000 (29.5)	27,100 (58)	27,100 (62)	27,100 (67.5)	24,050 (71.5)
30		19,200 (51)	19,200 (56.5)	19,200 (63)	19,200 (68)
35		14,200 (43.5)	14,200 (50)	14,200 (58.5)	14,200 (64)
40		10,550 (34.5)	10,550 (43)	10,550 (53.5)	10,550 (60)
45		7,905 (21.5)	7,905 (35)	7,905 (48.5)	7,905 (56)
50			5,840 (24.5)	5,840 (42.5)	5,840 (52)
60				2,880 (28)	2,880 (42.5)
Minimum boom angle (deg.) for indicated length (no load)					40
Maximum boom length (ft.) at 0 degree boom angle (no load)					74

NOTE: () Boom angles are in degrees.

#LMI operating code. Refer to LMI manual for operating instructions.

Capacities at Zero Degree Boom Angle					
Boom Angle	Main Boom Length in Feet				
	35	55	61	74	
0°	22,000 (28.2)	6,860 (47.4)	4,570 (53.8)	1,480 (66.6)	

NOTE: () Reference radii in feet.

A6-829-015117

RATED LIFTING CAPACITIES IN POUNDS WITHOUT COUNTERWEIGHT 35 FT. - 138 FT. BOOM

ON OUTRIGGERS FULLY EXTENDED - 360°

Radius in Feet	#0801								
	Main Boom Length in Feet								
	35	55	61	74	87	99	112	125	138
10	122,000 (65.5)	79,100 (76)	78,450 (77.5)	*57,050 (80)					
12	104,500 (62)	79,100 (73.5)	77,500 (75.5)	57,050 (78.5)	*43,300 (80)				
15	85,800 (56)	79,100 (70)	69,850 (72.5)	51,650 (76)	43,300 (78.5)	*32,100 (80)			
20	63,400 (44.5)	62,150 (64.5)	59,850 (67.5)	44,350 (71.5)	39,550 (75)	32,100 (77.5)	*30,050 (80)	*20,150 (80)	
25	46,000 (29.5)	44,900 (58)	45,200 (62)	38,750 (67.5)	33,800 (71.5)	32,100 (74.5)	30,050 (77)	20,150 (79)	*19,000 (80)
30		34,100 (51)	34,400 (56.5)	34,150 (63)	29,200 (68)	30,200 (71.5)	27,350 (74.5)	19,100 (76.5)	18,300 (78.5)
35		26,750 (43.5)	27,000 (50)	26,800 (58.5)	25,800 (64)	26,600 (68.5)	24,300 (71.5)	18,100 (74)	17,650 (76.5)
40		21,350 (34.5)	21,650 (43)	21,450 (53.5)	21,300 (60)	22,600 (65)	21,600 (69)	17,250 (72)	17,000 (74)
45	See Note 16	16,200 (21.5)	16,750 (35)	16,100 (48.5)	16,150 (56)	17,400 (61.5)	18,700 (66)	16,450 (69)	16,350 (72)
50			12,900 (24.5)	12,200 (42.5)	12,250 (52)	13,500 (58.5)	14,750 (63)	15,750 (66.5)	15,700 (69.5)
60				6,830 (28)	6,950 (42.5)	8,140 (51)	9,360 (57)	10,550 (61.5)	11,800 (65)
70					3,450 (30)	4,620 (42.5)	5,810 (50)	7,020 (56)	8,230 (60)
80						2,080 (32)	3,310 (42.5)	4,490 (49.5)	5,690 (55)
90							1,400 (33.5)	2,610 (43)	3,790 (49.5)
100								1,160 (35)	2,330 (43)
110									1,170 (36)
Minimum boom angle (deg.) for indicated length (no load)					22	27	31	33	34
Maximum boom length (ft.) at 0° boom angle (no load)					74				

NOTE: () Boom angles are in degrees.

#LMI operating code. Refer to LMI manual for instructions.

*This capacity is based upon maximum boom angle.

Lifting Capacities On Outriggers Fully Extended - 360° At Zero Degree Boom Angle									
Boom Angle	Main Boom Length in Feet								
	35	55	61	74					
0°	27,400 (28.2)	12,850 (47.4)	10,400 (53.8)	4,370 (66.6)					

NOTE: () Reference radii in feet.

A6-829-014848A

Boom Extension Sequence in %									
Inner-Mid	0	50	50	75	100	100	100	100	100
Mid	0	25	50	75	100	100	100	100	100
Outer-Mid	0	0	0	0	0	25	50	75	100
Fly	0	0	0	0	0	25	50	75	100

**31 FT. - 56 FT. FOLDING BOOM EXTENSION WITHOUT COUNTERWEIGHT
USING 125 FT. MAIN BOOM
ON OUTRIGGERS FULLY EXTENDED - 360°**

Radius in Feet	31 FT. LENGTH		56 FT. LENGTH	
	#0821	#0823	#0841	#0843
	1.5° OFFSET	45° OFFSET	1.5° OFFSET	45° OFFSET
30	*11,500 (80)			
35	11,500 (78.5)			
40	11,500 (77)		6,950 (79.5)	
45	11,500 (75)	*8,000 (80)	6,780 (78.5)	
50	11,000 (73.5)	6,810 (78.5)	6,620 (77)	
60	10,050 (70)	6,490 (74.5)	6,290 (74)	
70	9,220 (66)	6,400 (70.5)	5,960 (71)	*3,700 (80)
80	6,670 (62)	6,350 (66)	5,640 (67.5)	3,520 (76.5)
90	4,650 (57.5)	5,710 (61.5)	5,260 (64.5)	3,400 (72.5)
100	3,080 (53)	3,860 (56.5)	4,270 (60.5)	3,290 (68.5)
110	1,830 (47.5)	2,380 (51)	2,900 (56.5)	3,190 (64)
120			1,790 (52)	3,110 (59.5)
130				1,920 (54)
Minimum boom angle (deg.) for indicated length (no load)	42	46	48	51
Maximum boom length (ft.) at 0 degree boom angle (no load)	74		61	

NOTE: () Boom angles are in degrees.

A6-829-014900

#LMI operating code. Refer to LMI manual for instructions.

*This capacity is based upon maximum boom angle.

1. All capacities above the bold line are based on structural strength of boom extension and do not exceed 85% of tipping loads, in accordance with SAE J-765.
2. 31 ft. and 56 ft. folding boom extension lengths may be used for single line lifting service only.
3. For main boom lengths less than 125 ft. with the boom extension erected, the rated loads are determined by boom angle. Use only the column which corresponds to the boom extension length and offset for which the machine is set up. For boom angles not shown, use rating of the next lower boom angle.
4. **WARNING:** Operation of this machine with heavier loads than the capacities listed is strictly prohibited. Machine tipping with boom extension occurs rapidly and without advance warning.
5. Boom angle is the angle above or below horizontal of the longitudinal axis of the boom base section after lifting rated load.
6. Capacities listed are with outriggers properly extended and vertical jacks set only.

**31 FT. - 56 FT. FOLDING BOOM EXTENSION WITHOUT COUNTERWEIGHT
USING 138 FT. MAIN BOOM
ON OUTRIGGERS FULLY EXTENDED - 360°**

Radius in Feet	31 FT. LENGTH		56 FT. LENGTH	
	#0821	#0823	#0841	#0843
	1.5° OFFSET	45° OFFSET	1.5° OFFSET	45° OFFSET
35	9,500 (79.5)			
40	9,500 (78)		*5,500 (80)	
45	9,500 (76.5)		5,400 (79.5)	
50	9,500 (75)	*7,800 (80)	5,300 (78)	
60	9,110 (71.5)	6,740 (77)	5,100 (75.5)	
70	8,450 (68.5)	6,460 (73.5)	4,900 (72.5)	*3,600 (80)
80	7,210 (64.5)	6,350 (69.5)	4,700 (69.5)	3,500 (77.5)
90	5,100 (60.5)	6,280 (65.5)	4,500 (66.5)	3,400 (74)
100	3,470 (56.5)	4,420 (61)	4,300 (63.5)	3,300 (70.5)
110	2,170 (52)	2,910 (56.5)	3,210 (59.5)	3,200 (67)
120	1,120 (47)	1,680 (51)	2,170 (56)	3,090 (63)
130			1,260 (52)	2,040 (58.5)
140				1,160 (53.5)
Minimum boom angle (deg.) for indicated length (no load)	46	49	50	52
Maximum boom length (ft.) at 0° boom angle (no load)	74		61	

NOTE: () Boom angles are in degrees.

A6-829-014899A

#LMI operating code. Refer to LMI manual for instructions.

*This capacity is based upon maximum boom angle.

1. All capacities above the bold line are based on structural strength of boom extension and do not exceed 85% of tipping loads, in accordance with SAE J-765.
2. 31 ft. and 56 ft. folding boom extension lengths may be used for single line lifting service only.
3. For main boom lengths between 125 ft. and fully extended with the boom extension erected, the rated loads are determined by boom angle. Use only the column which corresponds to the boom extension length and offset for which the machine is set up. For boom angles not shown, use rating of the next lower boom angle.
4. **WARNING:** Operation of this machine with heavier loads than the capacities listed is strictly prohibited. Machine tipping with boom extension occurs rapidly and without advance warning.
5. Boom angle is the angle above or below horizontal of the longitudinal axis of the boom base section after lifting rated load.
6. Capacities listed are with outriggers properly extended and vertical jacks set only.

RATED LIFTING CAPACITIES IN POUNDS WITHOUT COUNTERWEIGHT 35 FT. - 138 FT. BOOM

ON OUTRIGGERS 50% EXTENDED (17' 4" SPREAD) - 360°

Radius in Feet	#4801								
	Main Boom Length in Feet								
	35	55	61	74	87	99	112	125	138
10	112,500 (65.5)	79,100 (76)	78,450 (77.5)	*57,050 (80)					
12	99,350 (62)	79,100 (73.5)	77,500 (75.5)	57,050 (78.5)	*43,300 (80)				
15	84,050 (56)	73,500 (70)	69,850 (72.5)	51,650 (76)	43,300 (78.5)	*32,100 (80)			
20	50,150 (44.5)	44,350 (64.5)	43,550 (67.5)	40,400 (71.5)	37,800 (75)	32,100 (77.5)	*30,050 (80)	*20,150 (80)	
25	30,950 (29.5)	29,150 (58)	29,650 (62)	27,650 (67.5)	26,000 (71.5)	26,550 (74.5)	26,750 (77)	20,150 (79)	*19,000 (80)
30		19,250 (51)	20,050 (56.5)	19,700 (63)	18,650 (68)	19,500 (71.5)	19,950 (74.5)	19,100 (76.5)	18,300 (78.5)
35		13,100 (43.5)	13,800 (50)	13,300 (58.5)	13,200 (64)	14,450 (68.5)	15,250 (71.5)	15,700 (74)	15,950 (76.5)
40	See Note 16	8,950 (34.5)	9,520 (43)	8,990 (53.5)	8,960 (60)	10,150 (65)	11,300 (69)	12,300 (72)	12,650 (74)
45		5,930 (21.5)	6,420 (35)	5,840 (48.5)	5,850 (56)	7,030 (61.5)	8,200 (66)	9,380 (69)	10,100 (72)
50			4,070 (24.5)	3,450 (42.5)	3,490 (52)	4,660 (58.5)	5,820 (63)	6,980 (66.5)	8,130 (69.5)
60						1,310 (51)	2,450 (57)	3,590 (61.5)	4,730 (65)
70								1,310 (56)	2,440 (60)
0.1A (lbs.)	1,270	1,340	1,310	1,330	1,350	1,230	1,140	1,070	1,010
Minimum boom angle (deg.) for indicated length (no load)				30	43	48	51	54	56
Maximum boom length (ft.) at 0 degree boom angle (no load)				61					

NOTE: () Boom angles are in degrees.

#LMI operating code. Refer to LMI manual for instructions.

*This capacity is based upon maximum boom angle.

Lifting Capacities On Outriggers 50% Extended - 360° At Zero Degree Boom Angle									
Boom Angle	Main Boom Length in Feet								
	35	55	61						
0°	23,900 (28.2)	4,780 (47.4)	2,660 (53.8)						

NOTE: () Reference radii in feet.

A6-829-014850A

Boom Extension Sequence in %									
Inner-Mid	0	50	50	75	100	100	100	100	100
Mid	0	25	50	75	100	100	100	100	100
Outer-Mid	0	0	0	0	0	25	50	75	100
Fly	0	0	0	0	0	25	50	75	100

LIFTING OFF MAIN BOOM NOSE (35 FT. - 138 FT. BOOM) WITH:	
25 ft. Fly Section (Stowed on Boom Base Section)	440 lbs.
31 ft. Fixed Extension (Stowed on Boom Base Section)	1,110 lbs.
31 ft. Fixed Extension (Erected)	4,830 lbs.
31-56 ft. Folding Extension (Stowed on Boom Base Section)	1,550 lbs.
31-56 ft. Folding Extension (Erected)	10,700 lbs.
LIFTING OFF 31 FT. BOOM EXTENSION WITH:	
25 ft. Fly Section (Stowed on Boom Base Section)	440 lbs.
25 ft. Fly Section (Erected)	Not Permitted
25 ft. Fly Section (Stowed on 31 ft. Extension)	Not Permitted

*Reduction of main boom capacities

AUXILIARY BOOM NOSE	127 lbs.
HOOKBLOCKS and HEADACHE BALLS:	
75 Ton, 6 Sheave w/cheekplates	2,299 lbs.+
75 Ton, 6 Sheave w/o cheekplates	1,711 lbs.+
45 Ton, 3 Sheave w/cheekplates	1,095 lbs.+
45 Ton, 3 Sheave w/o cheekplates	830 lbs.+
15 Ton, 1 Sheave	423 lbs.+
10 Ton Headache Ball	560 lbs.+

+Refer to rating plate for actual weight.

When lifting over swingaway and/or jib combinations, deduct total weight of all load handling devices reeved over main boom nose directly from swingaway or jib capacity.

NOTE: All load handling devices and boom attachments are considered part of the load and suitable allowances **MUST BE MADE** for their combined weights. Weights are for Grove furnished equipment.

TIRE INFLATION - PSI (BAR)		
SIZE (FRONT & REAR)	TRA CODE	LIFTING SERVICE , GENERAL TRAVEL AND EXTENDED TRAVEL
		STATIC, CREEP & 2.5 MPH (4.0 KPH)
MICHELIN 33.25R29 XRB**	----	75 (5.2)
33.25x29 (32)	E-3	65 (4.5) (SEE OPERATOR'S MANUAL FOR EXTENDED ROADING)

LINE PULLS AND REEVING INFORMATION

HOISTS	CABLE SPECS.	PERMISSIBLE LINE PULLS	NOMINAL CABLE LENGTH
Main & Aux. Model 30	3/4" (19 mm) 18x19Class or 35x7 Rotation Resistant Min. Breaking Str. 64,600 lbs.	12,920 lbs.	620 ft.
Main & Aux. Model 30	3/4" (19 mm) 6x37 Class EIPS IWRC Special Flexible Min. Breaking Str. 58,800 lbs.	12,920 lbs.	620 ft.

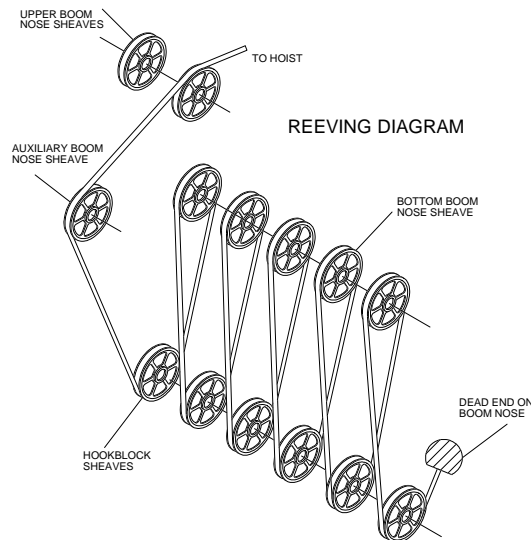

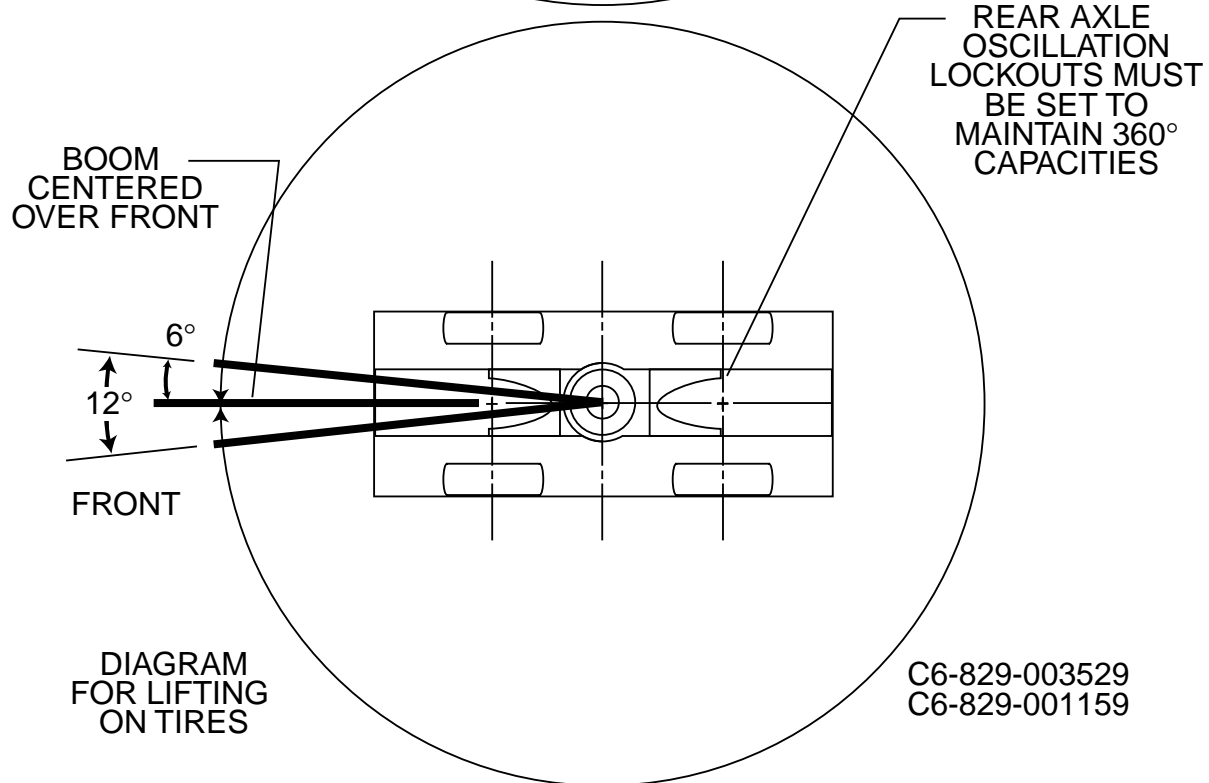
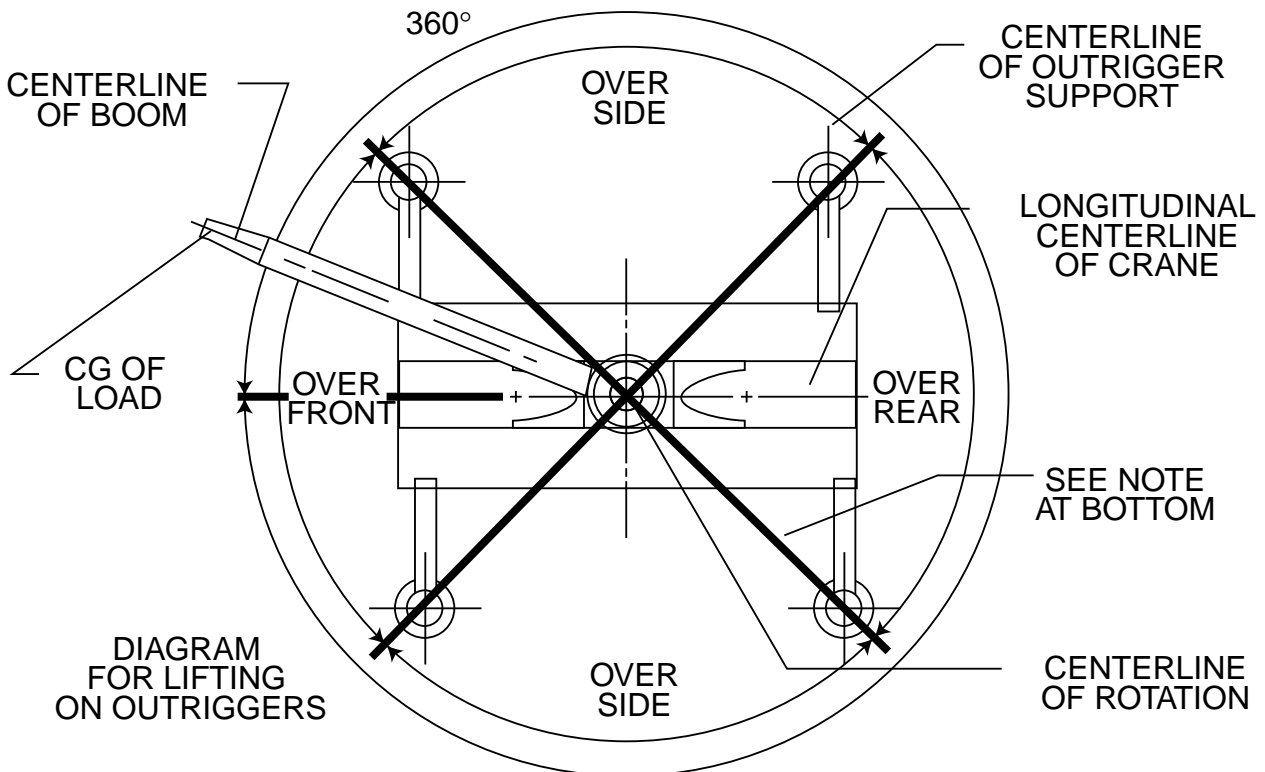

C6-829-003529
C6-829-001159

BOLD LINES DETERMINE THE LIMITING POSITION OF ANY LOAD FOR OPERATION WITHIN WORKING AREAS INDICATED

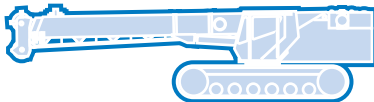
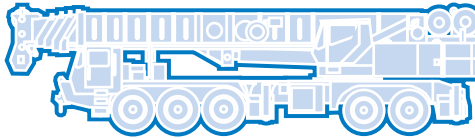
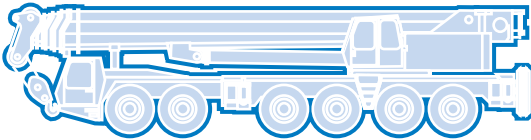
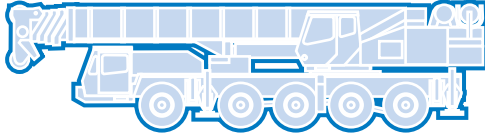
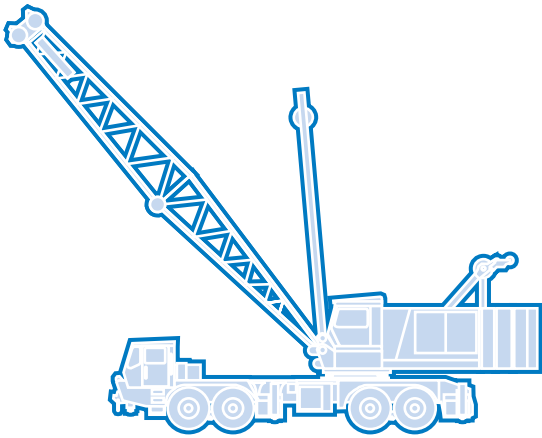

Grove Worldwide – World Headquarters

1565 Buchanan Trail East
P.O. Box 21
Shady Grove, Pennsylvania 17256,
U.S.A.
Tel: [Int + 1] (717) 597-8121
Fax: [Int + 1] (717) 597-4062
Western Hemisphere, Asia/Pacific

Grove Europe Limited*

Sunderland SR4 6TT, England
Tel: [Int + 44] 191 565-6281
Fax: [Int + 44] 191 564-0442
Europe, Africa, Middle East

Deutsche Grove GmbH

Sales and Service
Helmholtzstrasse 12, Postfach 5026
D-40750 Langenfeld, Germany
Tel: [Int + 49] (2173) 8909-0
Fax: [Int + 49] (2173) 8909-30

Wilhelmshaven Works

Industriegelände West, Postfach 1853
D-26358 Wilhelmshaven, Germany
Tel: [Int + 49] (4421) 294-0
Fax: [Int + 49] (4421) 294-301

Grove Asia/Pacific - Regional Office

171 Chin Swee Road
#10-09 San Centre
Singapore 0316
Tel: [Int + 65] 536-6112
Fax: [Int + 65] 536-6119
Asia/Pacific, Near East

*Grove Europe Limited, Registered in England,
Number 1845128, Registered office, Crown
Works, Pallion, Sunderland, Tyne & Wear,
England SR4 6TT

Grove China - Representative Office

Beijing Hotel Room 6074
No. 33 East Chang An Avenue
Beijing, 100004, China
Tel: [Int + 86] (10) 513-7766
Fax: [Int + 86] (10) 513-7307

Grove Middle East

P.O. Box 290
Dubai, United Arab Emirates
Tel: (Int + 971) (4) 378400
Fax: (Int + 971) (4) 373660

Lifetime Customer Support

Western Hemisphere, Asia/Pacific
1086 Wayne Avenue
Chambersburg, Pennsylvania USA
Tel: [Int + 1] (717) 263-5100
Fax: [Int + 1] (717) 267-0404

Europe, Africa, Middle East

Sunderland SR4 6TT, England
Tel: [Int + 44] 191 565-6281
Parts Fax: [Int + 44] 191 510-9242
Service Fax: [Int + 44] 191 510-9560

Constant improvement and engineering progress make it necessary that we reserve the right to make specification, equipment, and price changes without notice. Illustrations shown may include optional equipment and accessories and may not include all standard equipment.

Distributed By: