



HC 80
80tons capacity
Crawler Crane

DATASHEET IMPERIAL

HC 80



WORKS FOR YOU.™

	Page:
Key	3
Highlights	3
Dimensions	4
Range Diagram 47HI Boom	6
Load Charts With 47HI Offset Tip Boom	7
Range Diagram 46HI Boom	11
Load Charts With 46HI Angle Boom, 4 Sheave Tip	12
Range Diagram 47HI Boom, #9HL Jib	16
Load Charts With 47HI Boom, #9HL Jib	17
Range Diagram 46 HI Boom, #9 Angle Jib	21
Load Charts With 46HI Boom, #9 Angle Jib	22
Technical Description Hydraulic Crawler Crane	28
Transport Example for HC 80	29

HIGHLIGHTS

HC 80

- ▶ 80 tons maximum lifting capacity
- ▶ 200 ft maximum length of main boom
- ▶ 170 + 60 ft maximum boom and jib
- ▶ 240 ft maximum boom and luffing jib length
- ▶ Power up/down and freefall on main, auxiliary and optional third drum
- ▶ Quiet, spacious operator's cab
- ▶ Excellent visibility
- ▶ Two speed travel
- ▶ Superior transportability – 88,000 lb transport weight includes sideframes and boom inner



KEY



Counterweight

DIMENSIONS

HC 80

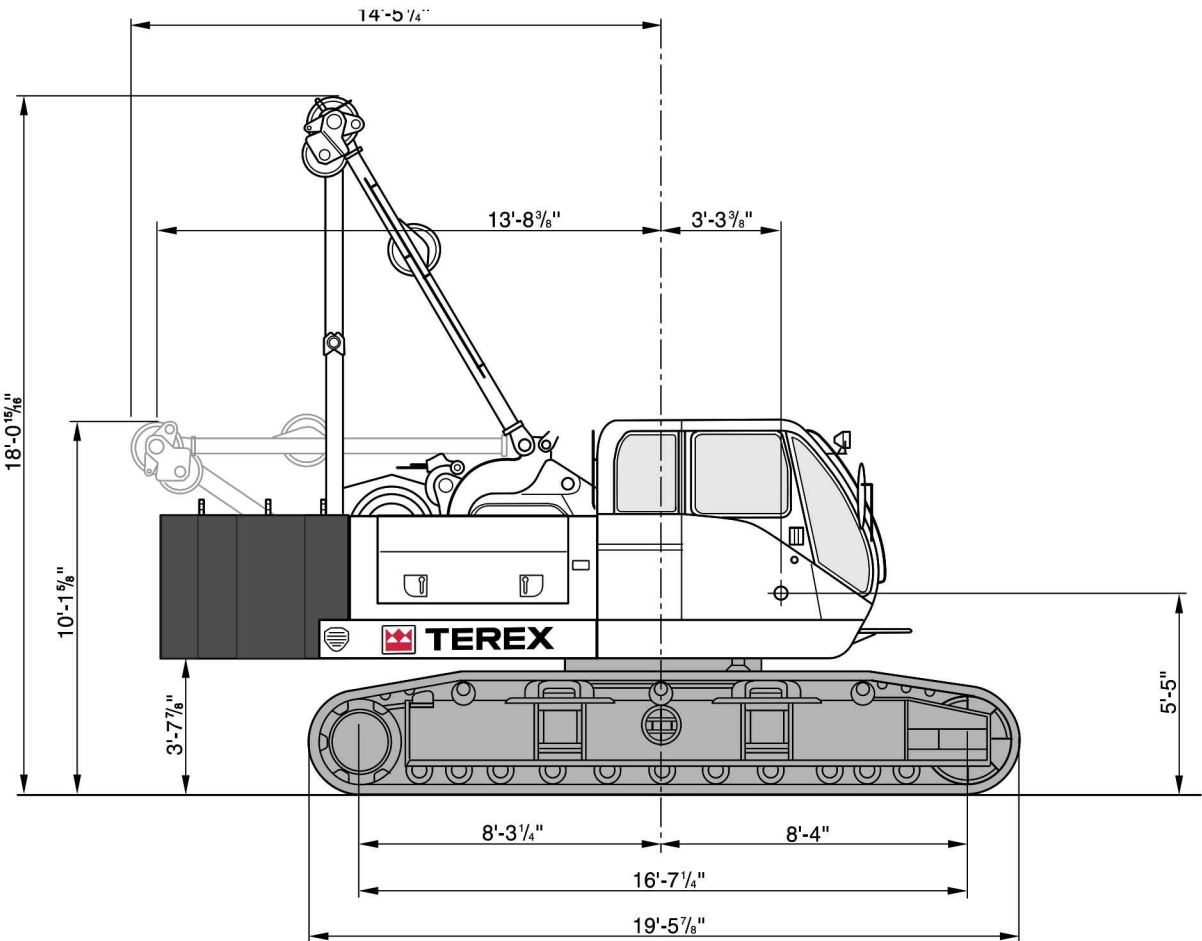

DIMENSIONS

HC 80

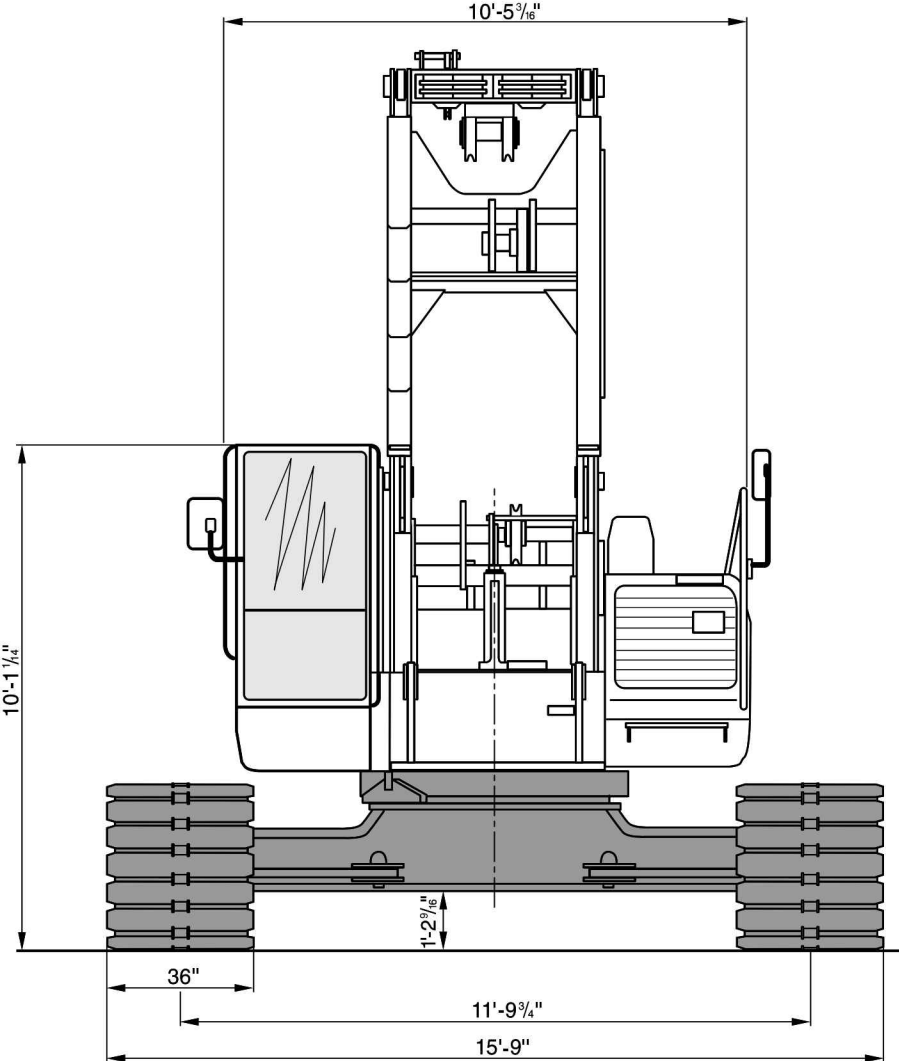

RANGE DIAGRAM

HC 80

47HI Boom

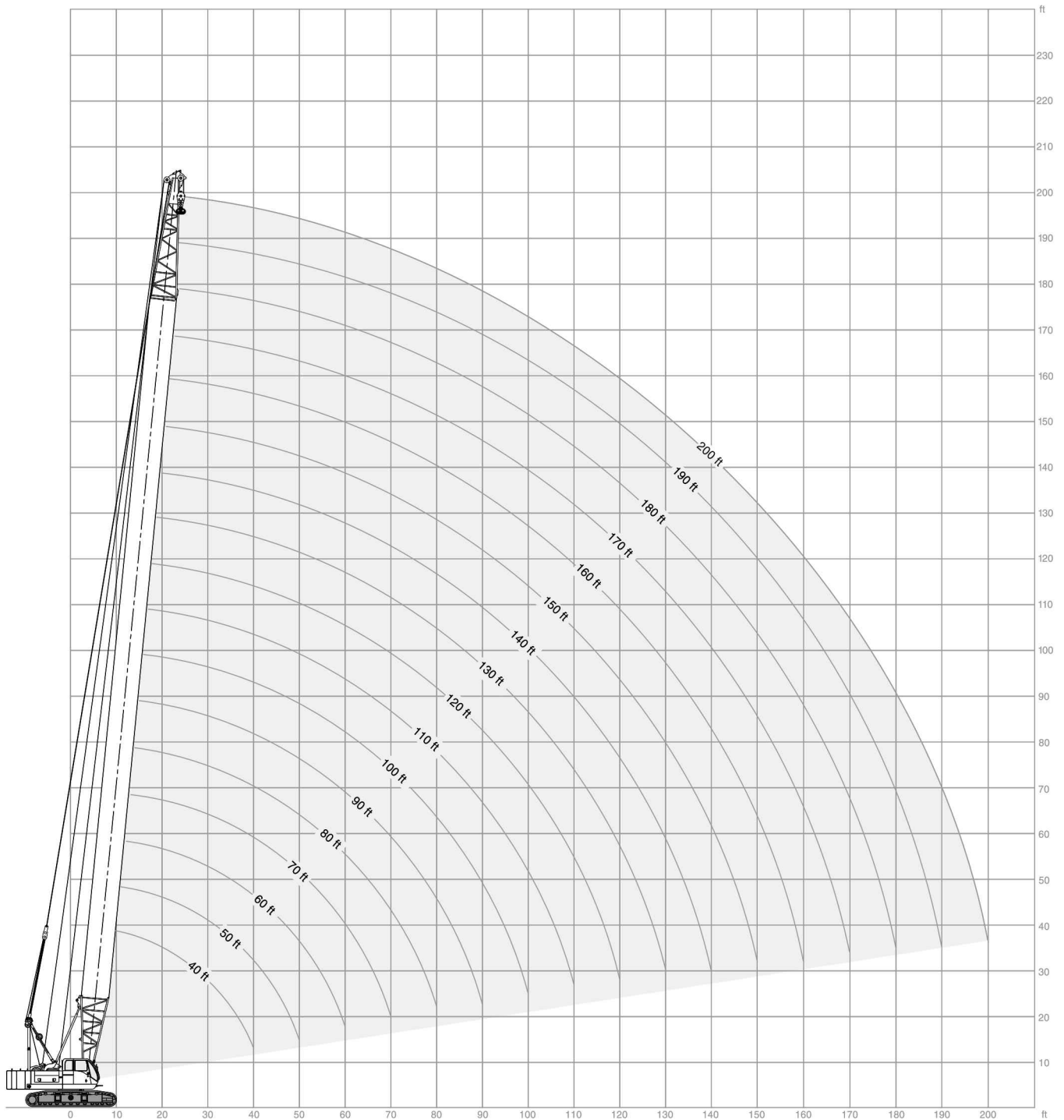

LOAD CHART

HC 80

With 47HI Offset Tip Boom

58,100 lb				360°				ANSI B 30.5			
40' Boom length				80' Boom length							
Radius (Feet)	Boom Angle (Degrees)	Side Frames Extended (Pounds)	From Boom Pt. to Ground (Feet)	Radius (Feet)	Boom Angle (Degrees)	Side Frames Extended (Pounds)	From Boom Pt. to Ground (Feet)				
11	80.5	160,000*	45	17	80.9	109,250*	84				
12	79.0	160,000*	45	20	78.8	87,470	84				
15	74.6	141,480	44	25	75.1	62,960	83				
20	67.0	87,810	42	30	71.3	48,880	81				
25	58.8	63,360	40	35	67.5	39,870	79				
30	49.9	49,350	36	40	63.5	33,480	77				
35	39.5	40,320	31	50	55.1	25,140	71				
40	25.8	33,970	23	60	45.8	20,000	63				
				70	34.5	16,430	51				
				80	17.9	13,830	30				
50' Boom length				90' Boom length							
13	80.1	160,000*	55	19	80.7	94,540	94				
15	77.8	141,440	54	20	80.0	87,330	94				
20	71.8	87,750	53	25	76.8	62,810	93				
25	65.6	63,280	51	30	73.5	48,720	92				
30	59.1	49,250	48	35	70.1	39,720	90				
35	52.0	40,220	45	40	66.7	33,320	88				
40	44.2	33,860	40	50	59.5	24,970	83				
50	22.9	25,540	25	60	51.7	19,840	76				
				70	43.0	16,260	67				
				80	32.5	13,660	54				
				90	16.9	11,690	32				
60' Boom length				100' Boom length							
14	80.8	145,370*	65	21	80.4	80,910	104				
15	79.8	141,380	64	25	78.1	62,690	103				
20	74.9	87,660	63	30	75.2	48,580	102				
25	69.9	63,170	62	35	72.2	39,590	101				
30	64.7	49,120	60	40	69.1	33,190	99				
35	59.2	40,100	57	50	62.8	24,840	94				
40	53.4	33,730	54	60	56.1	19,720	88				
50	40.2	25,400	44	70	48.9	16,130	81				
60	20.8	20,230	27	80	40.7	13,540	71				
				90	30.7	11,560	56				
				100	16.0	10,010	33				
70' Boom length				110' Boom length							
16	80.5	125,040*	74	22	80.8	72,040*	114				
20	77.1	87,590	74	25	79.2	62,530	113				
25	72.9	63,090	72	30	76.5	48,420	112				
30	68.5	49,040	71	35	73.8	39,430	111				
35	64.0	40,020	68	40	71.1	33,020	109				
40	59.3	33,640	66	50	65.5	24,650	105				
50	49.2	25,310	58	60	59.6	19,560	100				
60	37.0	20,150	48	70	53.3	15,970	94				
70	19.2	16,580	28	80	46.4	13,360	85				
				90	38.7	11,380	74				
				100	29.2	9,840	59				
				110	15.2	8,590	34				

LOAD CHART

HC 80

With 47HI Offset Tip Boom

58,100 lb				360°				ANSI B 30.5			
120' Boom length				150' Boom length							
Radius (Feet)	Boom Angle (Degrees)	Side Frames Extended (Pounds)	From Boom Pt. to Ground (Feet)	Radius (Feet)	Boom Angle (Degrees)	Side Frames Extended (Pounds)	From Boom Pt. to Ground (Feet)				
24	80.6	60,160*	124	28	80.9	36,630*	154				
25	80.1	60,160*	124	30	80.2	36,540*	153				
30	77.7	48,260	123	35	78.2	36,070*	152				
35	75.2	39,260	121	40	76.3	32,360	151				
40	72.7	32,850	120	50	72.3	23,960	148				
50	67.6	24,470	116	60	68.2	18,900	145				
60	62.3	19,390	112	70	64.0	15,310	140				
70	56.8	15,800	106	80	59.7	12,690	135				
80	50.8	13,190	98	90	55.1	10,710	128				
90	44.3	11,210	89	100	50.3	9,150	121				
100	37.0	9,660	78	110	45.1	7,890	112				
110	28.0	8,410	62	120	39.4	6,860	101				
120	14.5	7,390	36	130	32.9	6,000	87				
				140	24.9	5,270	69				
				150	12.9	4,650	39				
130' Boom length				160' Boom length							
Radius (Feet)	Boom Angle (Degrees)	Side Frames Extended (Pounds)	From Boom Pt. to Ground (Feet)	Radius (Feet)	Boom Angle (Degrees)	Side Frames Extended (Pounds)	From Boom Pt. to Ground (Feet)				
25	80.9	50,970*	134	30	80.8	31,770*	163				
30	78.6	48,100	133	35	79.0	31,370*	162				
35	76.4	39,120	132	40	77.1	30,790*	161				
40	74.1	32,700	130	50	73.4	23,800	159				
50	69.4	24,320	127	60	69.7	18,750	155				
60	64.7	19,240	123	70	65.8	15,150	151				
70	59.6	15,650	118	80	61.8	12,530	146				
80	54.4	13,040	111	90	57.6	10,550	141				
90	48.7	11,060	103	100	53.2	8,990	134				
100	42.5	9,510	93	110	48.6	7,730	125				
110	35.4	8,250	81	120	43.6	6,690	116				
120	26.8	7,230	64	130	38.1	5,830	104				
130	13.9	6,380	37	140	31.8	5,100	90				
				150	24.1	4,480	71				
				160	12.5	3,950	40				
140' Boom length				170' Boom length							
Radius (Feet)	Boom Angle (Degrees)	Side Frames Extended (Pounds)	From Boom Pt. to Ground (Feet)	Radius (Feet)	Boom Angle (Degrees)	Side Frames Extended (Pounds)	From Boom Pt. to Ground (Feet)				
27	80.7	42,380*	144	31	81.0	27,710*	173				
30	79.5	42,370*	143	35	79.6	27,340*	173				
35	77.4	38,950	142	40	77.9	26,810*	172				
40	75.3	32,530	141	50	74.4	23,610	169				
50	71.0	24,140	138	60	70.9	18,580	166				
60	66.6	19,070	134	70	67.3	14,980	162				
70	62.0	15,480	129	80	63.6	12,360	158				
80	57.3	12,860	123	90	59.7	10,360	152				
90	52.2	10,880	116	100	55.7	8,800	146				
100	46.8	9,330	108	110	51.5	7,540	139				
110	40.9	8,070	97	120	47.1	6,510	130				
120	34.1	7,040	84	130	42.2	5,650	120				
130	25.8	6,180	66	140	36.9	4,920	108				
140	13.4	5,470	38	150	30.8	4,290	93				
				160	23.4	3,750	73				
				170	12.1	3,290	41				

LOAD CHART

HC 80

With 47HI Offset Tip Boom

58,100 lb				360°				ANSI B 30.5			
180' Boom length				200' Boom length							
Radius (Feet)	Boom Angle (Degrees)	Side Frames Extended (Pounds)	From Boom Pt. to Ground (Feet)	Radius (Feet)	Boom Angle (Degrees)	Side Frames Extended (Pounds)	From Boom Pt. to Ground (Feet)	Radius (Feet)	Boom Angle (Degrees)	Side Frames Extended (Pounds)	From Boom Pt. to Ground (Feet)
33	80.9	24,240*	183	36	80.9	16,750*	203				
35	80.2	24,110*	183	40	79.7	16,230*	202				
40	78.6	23,210*	182	50	76.8	15,000*	200				
50	75.3	20,080*	180	60	73.8	13,800*	198				
60	72.0	18,410	177	70	70.8	12,770*	194				
70	68.6	14,800	173	80	67.8	11,840	191				
80	65.1	12,180	169	90	64.6	9,840	186				
90	61.6	10,190	164	100	61.4	8,270	181				
100	57.9	8,630	158	110	58.1	7,010	175				
110	54.0	7,360	151	120	54.6	5,970	169				
120	50.0	6,330	143	130	51.0	5,100	161				
130	45.7	5,460	134	140	47.2	4,370	152				
140	41.0	4,720	123	150	43.2	3,740	142				
150	35.8	4,100	111	160	38.8	3,190	131				
160	29.9	3,550	95	170	33.9	2,710	117				
170	22.7	3,080	75	180	28.4	2,300	100				
180	11.8	2,690	42	190	21.5	1,940	79				
				200	11.2	1,560*	44				
190' Boom length											
35	80.7	19,320*	193								
40	79.2	18,660*	192								
50	76.1	17,360*	190								
60	73.0	16,110*	187								
70	69.8	14,640	184								
80	66.5	12,010	180								
90	63.2	10,020	175								
100	59.8	8,460	170								
110	56.2	7,200	163								
120	52.5	6,160	156								
130	48.5	5,290	148								
140	44.4	4,550	138								
150	39.8	3,930	127								
160	34.8	3,390	114								
170	29.1	2,910	98								
180	22.1	2,500	77								
190	11.5	2,150	43								

NOTES TO LIFTING CAPACITY

HC 80

Main Boom Chart Information

47HI Boom

Boom size	20' 47HI Inner	10' 47H Center	20' 47H Center	30' 47H Center	20' 47HI Outer
40	1	0	0	0	1
50	1	1	0	0	1
60	1	0	1	0	1
70	1	0	0	1	1
80	1	1	0	1	1
90	1	0	1	1	1
100	1	0	0	2	1
110	1	1	0	2	1
120	1	0	1	2	1
130	1	0	0	3	1
140	1	1	0	3	1
150	1	0	1	3	1
160	1	0	0	4	1
170	1	1	0	4	1
180	1	0	1	4	1
190	1	0	0	5	1
200	1	1	0	5	1

For Main Boom Use Only

Load Hoisting Information – 7/8 Inch Diameter EIPS Wire Rope			
Maximum Lifting Capacity (lb)	Minimum Parts of Line	Maximum hoisting distance (feet)	
		Main hoist	Auxiliary hoist
160.000	8	73	73
159.180	7	84	84
136.440	6	98	98
113.700	5	117	117
90.960	4	147	147
68.220	3	196	196
45.480	2	294	294
22.740	1	588	588

RANGE DIAGRAM

HC 80

46HI Boom

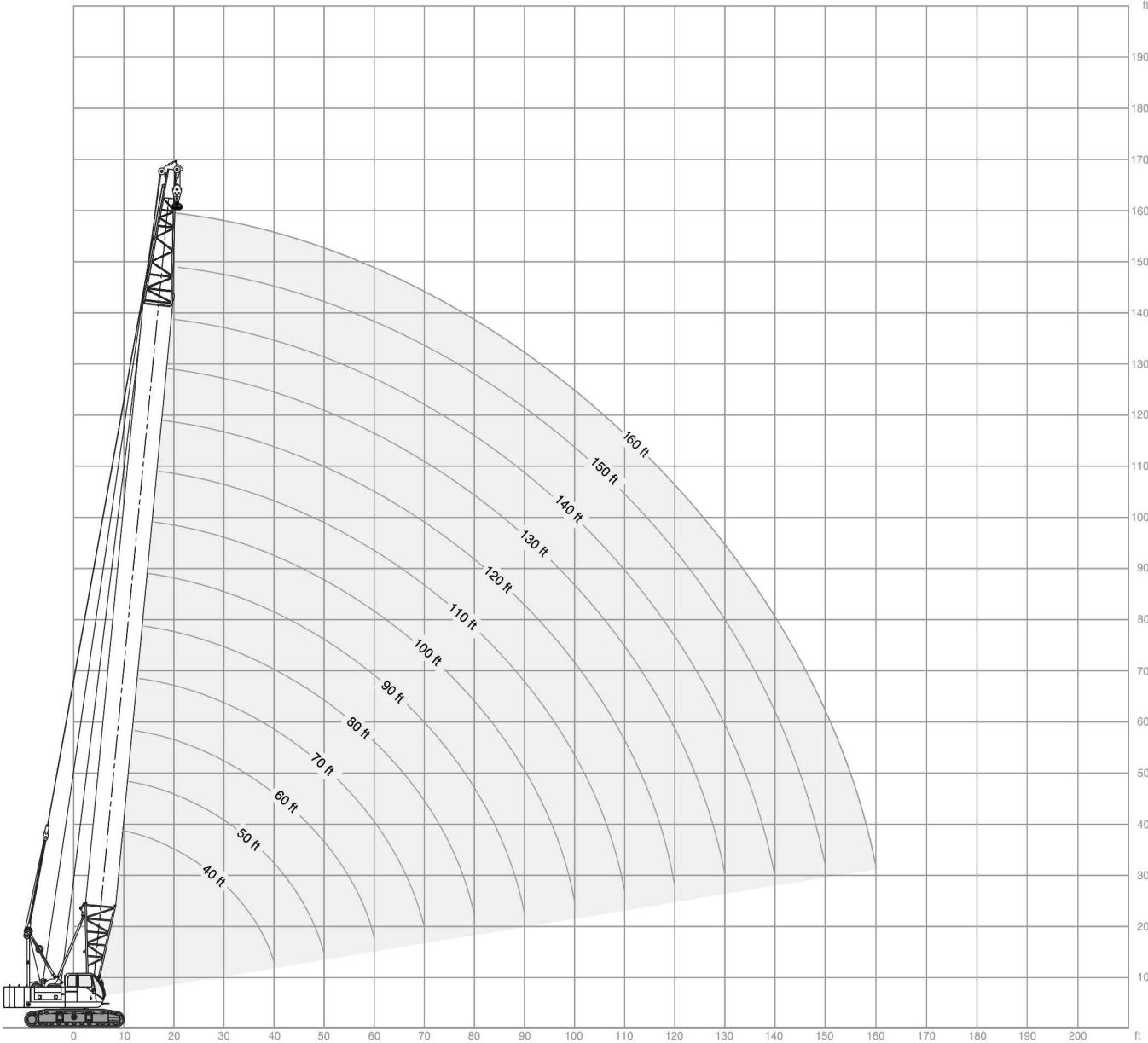

LOAD CHART

HC 80

With 46HI Angle Boom, 4 Sheave Tip

58,100 lb				360°				ANSI B 30.5			
40' Boom length				80' Boom length							
Radius (Feet)	Boom Angle (Degrees)	360 Degree Rating (Pounds)	From Boom Pt. to Ground (Feet)	Radius (Feet)	Boom Angle (Degrees)	Side Frames Extended (Pounds)	From Boom Pt. to Ground (Feet)				
10	80.9	160,000*	45	17	80.4	94,370*	84				
12	77.9	160,000*	45	20	78.2	87,000	84				
15	73.5	141,160	44	25	74.5	62,490	83				
20	65.9	87,490	42	30	70.8	48,410	81				
25	57.7	63,040	39	35	66.9	39,400	79				
30	48.8	49,030	36	40	63.0	33,020	77				
35	38.4	40,000	30	45	58.9	28,300	74				
40	24.7	33,650	22	50	54.6	24,670	71				
				55	50.1	21,870	67				
				60	45.2	19,540	62				
				65	39.9	17,600	57				
				70	34.0	15,970	50				
				75	26.9	14,570	42				
				80	17.4	13,370	29				
50' Boom length				90' Boom length							
Radius (Feet)	Boom Angle (Degrees)	360 Degree Rating (Pounds)	From Boom Pt. to Ground (Feet)	Radius (Feet)	Boom Angle (Degrees)	Side Frames Extended (Pounds)	From Boom Pt. to Ground (Feet)				
12	80.4	138,490*	55	18	80.8	84,440*	94				
15	76.9	128,430*	54	20	79.5	82,260*	94				
20	70.9	87,390	53	25	76.3	62,300	93				
25	64.7	62,910	51	30	73.0	48,210	91				
30	58.2	48,880	48	35	69.6	39,200	90				
35	51.2	39,850	44	40	66.2	32,810	88				
40	43.4	33,490	40	45	62.7	28,090	85				
45	34.2	28,790	34	50	59.0	24,460	83				
50	22.0	25,180	24	55	55.2	21,680	79				
				60	51.2	19,330	76				
				65	47.0	17,390	71				
				70	42.5	15,760	66				
				75	37.5	14,360	60				
				80	32.0	13,160	53				
				85	25.3	12,110	44				
				90	16.4	11,200	31				
60' Boom length				100' Boom length							
Radius (Feet)	Boom Angle (Degrees)	360 Degree Rating (Pounds)	From Boom Pt. to Ground (Feet)	Radius (Feet)	Boom Angle (Degrees)	Side Frames Extended (Pounds)	From Boom Pt. to Ground (Feet)				
14	80.1	119,630*	65	20	80.6	75,930*	104				
15	79.1	117,070*	64	25	77.7	62,120	103				
20	74.2	87,280	63	30	74.7	48,010	102				
25	69.2	62,790	61	35	71.7	39,020	100				
30	64.0	48,740	59	40	68.7	32,620	99				
35	58.5	39,710	57	45	65.6	27,890	96				
40	52.7	33,340	53	50	62.4	24,260	94				
45	46.4	28,630	49	55	59.1	21,490	91				
50	39.4	25,020	44	60	55.7	19,140	88				
55	31.1	22,200	36	65	52.2	17,200	84				
60	20.1	19,860	26	70	48.4	15,570	80				
				75	44.5	14,170	75				
				80	40.2	12,960	70				
				85	35.6	11,910	64				
				90	30.3	10,990	56				
				95	24.0	10,170	46				
				100	15.5	9,450	32				
70' Boom length											
Radius (Feet)	Boom Angle (Degrees)	360 Degree Rating (Pounds)	From Boom Pt. to Ground (Feet)								
15	80.7	106,350*	74								
20	76.5	87,110	73								
25	72.2	62,610	72								
30	67.9	48,550	70								
35	63.4	39,530	68								
40	58.7	33,150	65								
45	53.8	28,440	62								
50	48.5	24,820	58								
55	42.8	22,000	53								
60	36.4	19,660	47								
65	28.8	17,720	39								
70	18.6	16,100	28								



LOAD CHART

HC 80

With 46HI Angle Boom, 4 Sheave Tip

58,100 lb				360°				ANSI B 30.5			
110' Boom length				130' Boom length				140' Boom length			
Radius (Feet)	Boom Angle (Degrees)	Side Frames Extended (Pounds)	From Boom Pt. to Ground (Feet)	Radius (Feet)	Boom Angle (Degrees)	Side Frames Extended (Pounds)	From Boom Pt. to Ground (Feet)	Radius (Feet)	Boom Angle (Degrees)	Side Frames Extended (Pounds)	From Boom Pt. to Ground (Feet)
21	80.9	68,930*	114	24	81.0	55,570*	134	26	80.8	49,960*	144
25	78.8	61,920	113	25	80.6	55,210*	134	30	79.2	47,210	143
30	76.1	47,800	112	30	78.3	47,410	133	35	77.1	38,230	142
35	73.4	38,810	111	35	76.0	38,430	132	40	74.9	31,810	141
40	70.7	32,400	109	40	73.8	32,020	130	45	72.8	27,070	139
45	67.9	27,680	107	45	71.4	27,280	129	50	70.7	23,420	138
50	65.1	24,030	105	50	69.1	23,630	127	55	68.5	20,710	136
55	62.2	21,280	103	55	66.7	20,900	125	60	66.3	18,350	134
60	59.2	18,940	100	60	64.3	18,560	123	65	64.0	16,400	131
65	56.1	16,990	97	65	61.8	16,610	120	70	61.7	14,760	129
70	52.9	15,350	93	70	59.3	14,960	117	75	59.4	13,360	126
75	49.6	13,950	89	75	56.7	13,570	114	80	57.0	12,140	123
80	46.0	12,750	85	80	54.0	12,350	111	85	54.5	11,090	119
85	42.3	11,700	79	85	51.3	11,300	107	90	51.9	10,170	116
90	38.3	10,760	74	90	48.4	10,370	103	95	49.3	9,340	111
95	33.8	9,950	67	95	45.3	9,550	98	100	46.5	8,610	107
100	28.8	9,220	58	100	42.2	8,820	93	105	43.6	7,940	102
105	22.9	8,570	48	105	38.8	8,160	87	110	40.6	7,350	96
110	14.8	7,980	33	110	35.1	7,570	80	115	37.3	6,820	90
				115	31.1	7,030	72	120	33.8	6,330	83
				120	26.5	6,540	63	125	29.9	5,880	75
				125	21.0	6,100	52	130	25.5	5,480	66
				130	13.6	5,700	36	135	20.2	5,100	54
								140	13.1	4,760	37
120' Boom length											
23	80.7	61,380*	124								
25	79.7	60,000*	123								
30	77.3	47,630	122								
35	74.8	38,640	121								
40	72.4	32,230	120								
45	69.8	27,500	118								
50	67.3	23,850	116								
55	64.7	21,120	114								
60	62.0	18,760	111								
65	59.2	16,820	109								
70	56.4	15,180	105								
75	53.5	13,780	102								
80	50.5	12,570	98								
85	47.3	11,520	94								
90	44.0	10,590	89								
95	40.4	9,770	83								
100	36.6	9,040	77								
105	32.4	8,380	70								
110	27.6	7,790	61								
115	21.9	7,260	50								
120	14.2	6,780	35								

LOAD CHART

HC 80

With 46HI Angle Boom, 4 Sheave Tip

58,100 lb				360°				ANSI B 30.5			
150' Boom length				160' Boom length							
Radius (Feet)	Boom Angle (Degrees)	Side Frames Extended (Pounds)	From Boom Pt. to Ground (Feet)	Radius (Feet)	Boom Angle (Degrees)	Side Frames Extended (Pounds)	From Boom Pt. to Ground (Feet)				
28	80.7	43,920*	153	29	80.9	39,530*	163				
30	79.9	43,170*	153	30	80.5	39,370*	163				
35	77.9	38,020	152	35	78.7	37,830	162				
40	76.0	31,590	151	40	76.9	31,410	161				
45	74.0	26,850	150	45	75.0	26,650	160				
50	72.0	23,190	148	50	73.2	22,990	159				
55	70.0	20,490	146	55	71.3	20,310	157				
60	67.9	18,130	144	60	69.4	17,950	155				
65	65.9	16,190	142	65	67.4	16,000	153				
70	63.8	14,540	140	70	65.5	14,350	151				
75	61.6	13,130	137	75	63.5	12,950	149				
80	59.4	11,930	135	80	61.5	11,730	146				
85	57.2	10,870	131	85	59.4	10,680	143				
90	54.8	9,940	128	90	57.3	9,750	140				
95	52.5	9,110	124	95	55.2	8,920	137				
100	50.0	8,380	120	100	53.0	8,190	133				
105	47.5	7,720	116	105	50.7	7,530	129				
110	44.8	7,130	111	110	48.3	6,930	125				
115	42.1	6,590	106	115	45.9	6,390	120				
120	39.1	6,100	100	120	43.3	5,900	115				
125	36.0	5,650	94	125	40.7	5,450	110				
130	32.6	5,240	86	130	37.8	5,040	104				
135	28.9	4,860	78	135	34.8	4,660	97				
140	24.6	4,510	68	140	31.5	4,310	89				
145	19.5	4,190	56	145	27.9	3,990	80				
150	12.7	3,900	38	150	23.8	3,690	70				
				155	18.9	3,420	57				
				160	12.3	3,160	39				

NOTES TO LIFTING CAPACITY

HC 80

Main Boom Chart Information

46HI Boom

Boom size	20' 46HI Inner	10' 46HR Center	20' 46HR Center	40' 46HR Center	20' 46HI Outer
40	1	0	0	0	1
50	1	1	0	0	1
60	1	0	1	0	1
70	1	1	1	0	1
80	1	0	0	1	1
90	1	1	0	1	1
100	1	0	1	1	1
110	1	1	1	1	1
120	1	0	0	2	1
130	1	1	0	2	1
140	1	0	1	2	1
150	1	1	1	2	1
160	1	0	0	3	1

For Main Boom Use Only

Load Hoisting Information – 7/8 Inch Diameter EIPS Wire Rope			
Maximum Lifting Capacity (lb)	Minimum Parts of Line	Maximum hoisting distance (feet)	
		Main hoist	Auxiliary hoist
160.000	8	73	73
159.180	7	84	84
136.440	6	98	98
113.700	5	117	117
90.960	4	147	147
68.220	3	196	196
45.480	2	294	294
22.740	1	588	588

RANGE DIAGRAM

47HI Boom, #9HL Jib

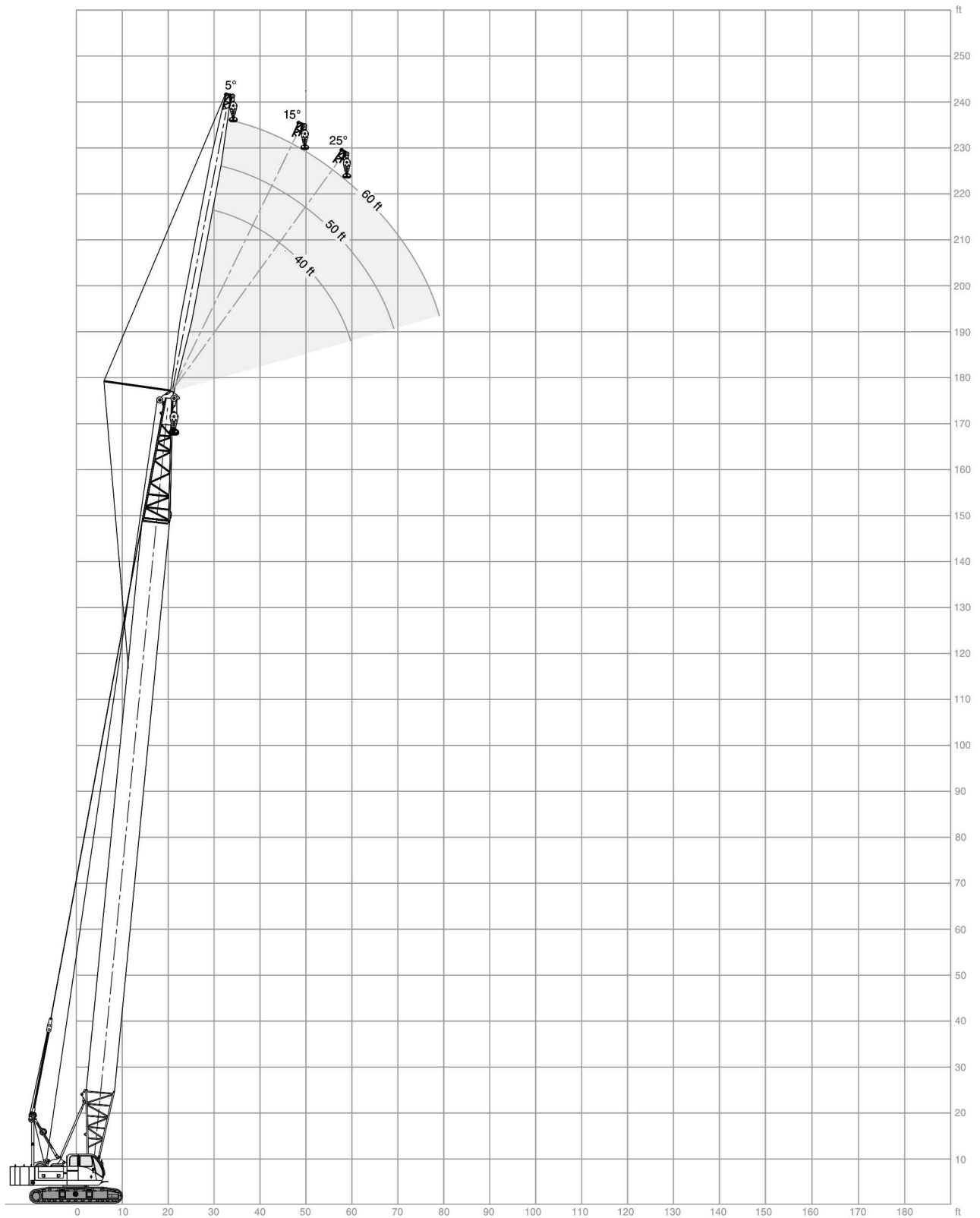

LOAD CHART

HC 80

With 47HI Boom, #9HL Jib

58,100 lb		360°				ANSI B 30.5									
40' Jib length															
Boom length	Jib Radius (Feet)	5.0 Deg offset Boom Angle	5.0 Deg offset Rating (Pounds)	15.0 Deg offset Boom Angle	15.0 Deg offset Rating (Pounds)	25.0 Deg offset Boom Angle	25.0 Deg offset Rating (Pounds)	Boom length	Jib Radius (Feet)	5.0 Deg offset Boom Angle	5.0 Deg offset Rating (Pounds)	15.0 Deg offset Boom Angle	15.0 Deg offset Rating (Pounds)	25.0 Deg offset Boom Angle	25.0 Deg offset Rating (Pounds)
100'	30	80.7	22,550*	-	-	-	-	140'	36	80.8	20,590*	-	-	-	-
	35	78.6	22,550*	-	-	-	-		40	79.5	20,210*	-	-	-	-
	40	76.5	22,190*	79.2	20,980*	-	-		50	76.3	19,260*	78.4	17,060*	80.4	13,890*
	50	72.2	21,500*	74.9	20,440*	77.5	19,540*		60	73.0	18,250*	75.1	16,430*	77.0	13,600*
	60	67.9	19,650	70.5	19,650	73.0	19,100*		70	69.6	15,280	71.7	15,280	73.6	13,240*
	70	63.4	16,060	66.0	16,070	68.4	16,070		80	66.2	12,680	68.2	12,680	70.1	12,680
	80	58.7	13,460	61.2	13,460	63.6	13,470		90	62.6	10,700	64.7	10,700	66.5	10,700
90	53.7	11,490	56.2	11,490	58.4	11,500	100	59.0	9,140	61.0	9,150	62.7	9,150		
100	48.4	9,950	50.8	9,950	52.9	9,950	110	55.1	7,890	57.1	7,900	58.8	7,900		
								120	51.1	6,860	53.1	6,870	54.7	6,870	
								130	46.9	6,010	48.8	6,010	50.3	6,010	
								140	42.3	5,280	44.1	5,280	45.5	5,290	
110'	31	80.9	22,530*	-	-	-	-	150'	37	81.0	17,400*	-	-	-	-
	35	79.3	22,530*	-	-	-	-		40	80.1	17,190*	-	-	-	-
	40	77.4	22,390*	79.9	21,090*	-	-		50	77.0	16,300*	79.0	14,440*	80.9	11,750*
	50	73.5	21,670*	76.0	20,540*	78.3	19,630*		60	73.9	15,370*	75.9	13,860*	77.7	11,470*
	60	69.4	19,440	71.9	19,440	74.2	19,190*		70	70.7	14,480*	72.7	13,220*	74.5	11,070*
	70	65.3	15,860	67.7	15,860	70.0	15,860		80	67.5	12,480	69.4	12,480	71.2	10,580*
	80	61.0	13,270	63.4	13,270	65.6	13,270		90	64.2	10,500	66.1	10,500	67.8	10,060*
90	56.5	11,290	58.9	11,290	61.0	11,290	100	60.8	8,950	62.7	8,950	64.4	8,950		
100	51.7	9,740	54.1	9,740	56.1	9,740	110	57.2	7,700	59.1	7,700	60.7	7,700		
110	46.6	8,490	48.9	8,490	50.8	8,490	120	53.5	6,670	55.4	6,670	57.0	6,670		
								130	49.7	5,810	51.5	5,810	53.0	5,810	
								140	45.5	5,080	47.3	5,080	48.7	5,090	
								150	41.1	4,460	42.8	4,460	44.1	4,460	
120'	33	80.7	22,520*	-	-	-	-	160'	39	80.9	14,750*	-	-	-	-
	35	80.0	22,520*	-	-	-	-		40	80.6	14,670*	-	-	-	-
	40	78.2	22,500*	80.6	21,150*	-	-		50	77.7	13,800*	79.6	12,290*	-	-
	50	74.5	21,850*	76.9	20,630*	79.1	19,480*		60	74.7	12,930*	76.6	11,740*	78.4	9,670*
	60	70.8	19,240	73.1	19,240	75.3	19,240		70	71.7	12,130*	73.6	11,100*	75.3	9,260*
	70	66.9	15,660	69.2	15,660	71.4	15,670		80	68.7	11,330*	70.5	10,480*	72.2	8,800*
	80	62.9	13,060	65.2	13,060	67.3	13,060		90	65.6	10,310	67.4	9,820*	69.1	8,290*
90	58.8	11,080	61.1	11,080	63.1	11,080	100	62.4	8,760	64.2	8,760	65.8	7,810*		
100	54.5	9,530	56.7	9,530	58.7	9,530	110	59.1	7,510	60.9	7,510	62.4	7,320*		
110	49.9	8,280	52.1	8,280	53.9	8,280	120	55.6	6,480	57.4	6,480	58.9	6,480		
120	45.0	7,250	47.1	7,260	48.8	7,260	130	52.1	5,620	53.8	5,620	55.3	5,620		
								140	48.3	4,890	50.0	4,890	51.4	4,900	
								150	44.3	4,270	46.0	4,270	47.3	4,270	
								160	40.0	3,720	41.6	3,720	42.8	3,730	
130'	34	80.9	22,500*	-	-	-	-	170'	41	80.9	14,750*	-	-	-	-
	35	80.6	22,500*	-	-	-	-		42	80.6	14,670*	-	-	-	-
	40	78.9	22,500*	-	-	-	-		50	77.7	13,800*	79.6	12,290*	-	-
	50	75.4	22,020*	77.7	20,170*	79.8	16,440*		60	74.7	12,930*	76.6	11,740*	78.4	9,670*
	60	71.9	19,060	74.1	19,060	76.2	16,240*		70	71.7	12,130*	73.6	11,100*	75.3	9,260*
	70	68.3	15,480	70.5	15,480	72.5	15,480		80	68.7	11,330*	70.5	10,480*	72.2	8,800*
	80	64.7	12,870	66.8	12,880	68.8	12,880		90	65.6	10,310	67.4	9,820*	69.1	8,290*
90	60.9	10,900	63.0	10,900	64.9	10,910	100	62.4	8,760	64.2	8,760	65.8	7,810*		
100	56.9	9,350	59.0	9,350	60.8	9,360	110	59.1	7,510	60.9	7,510	62.4	7,320*		
110	52.7	8,100	54.8	8,100	56.6	8,110	120	55.6	6,480	57.4	6,480	58.9	6,480		
120	48.3	7,070	50.4	7,080	52.0	7,080	130	52.1	5,620	53.8	5,620	55.3	5,620		
130	43.6	6,220	45.5	6,220	47.1	6,220	140	48.3	4,890	50.0	4,890	51.4	4,900		
								150	44.3	4,270	46.0	4,270	47.3	4,270	
								160	40.0	3,720	41.6	3,720	42.8	3,730	

LOAD CHART

HC 80

With 47HI Boom, #9HL Jib

58,100 lb		360°				ANSI B 30.5									
50' Jib length															
Boom length	Jib Radius (Feet)	5.0 Deg offset Boom Angle	5.0 Deg offset Rating (Pounds)	15.0 Deg offset Boom Angle	15.0 Deg offset Rating (Pounds)	25.0 Deg offset Boom Angle	25.0 Deg offset Rating (Pounds)	Boom length	Jib Radius (Feet)	5.0 Deg offset Boom Angle	5.0 Deg offset Rating (Pounds)	15.0 Deg offset Boom Angle	15.0 Deg offset Rating (Pounds)	25.0 Deg offset Boom Angle	25.0 Deg offset Rating (Pounds)
130'	37	80.8	21,570*	-	-	-	-	160'	41	81.0	13,810*	-	-	-	-
	40	79.8	21,570*	-	-	-	-		50	78.5	13,090*	80.8	11,330*	-	-
	50	76.5	21,210*	79.2	18,370*	-	-		60	75.7	12,280*	78.0	10,860*	80.1	8,710*
	60	73.2	19,110	75.9	17,960*	78.3	14,430*		70	72.9	11,490*	75.1	10,330*	77.2	8,420*
	70	69.9	15,520	72.5	15,520	74.9	14,230*		80	70.0	10,770*	72.2	9,800*	74.3	8,050*
	80	66.4	12,920	69.0	12,920	71.4	12,920		90	67.0	10,080*	69.2	9,220*	71.3	7,660*
	90	62.9	10,940	65.5	10,940	67.8	10,940		100	64.0	8,790	66.2	8,680*	68.2	7,240*
	100	59.2	9,380	61.8	9,390	64.0	9,390		110	60.9	7,540	63.1	7,540	65.0	6,830*
	110	55.4	8,130	57.9	8,140	60.1	8,140		120	57.7	6,510	59.9	6,510	61.8	6,410*
	120	51.4	7,100	53.8	7,110	55.9	7,110		130	54.4	5,650	56.5	5,650	58.4	5,660
130	47.1	6,250	49.5	6,250	51.5	6,250	140	50.9	4,920	53.0	4,920	54.8	4,930		
140'	38	80.9	19,020*	-	-	-	-	150	47.3	4,300	49.3	4,300	51.0	4,300	
	40	80.3	19,010*	-	-	-	-	160	43.4	3,760	45.4	3,760	47.0	3,770	
	50	77.3	18,100*	79.8	15,590*	-	-	170'	43	80.9	11,660*	-	-	-	-
	60	74.2	17,210*	76.6	15,150*	79.0	12,140*		50	79.0	11,130*	-	-	-	-
	70	71.0	15,330	73.5	14,540*	75.8	11,930*		60	76.4	10,340*	78.5	9,190*	80.6	7,380*
	80	67.8	12,720	70.2	12,720	72.5	11,570*		70	73.7	9,620*	75.8	8,650*	77.8	7,040*
	90	64.4	10,740	66.9	10,740	69.1	10,740		80	70.9	8,940*	73.1	8,150*	75.0	6,670*
	100	61.0	9,190	63.4	9,190	65.6	9,190		90	68.1	8,300*	70.3	7,600*	72.2	6,290*
	110	57.5	7,940	59.9	7,940	62.0	7,940		100	65.3	7,710*	67.4	7,120*	69.3	5,870*
	120	53.8	6,910	56.1	6,910	58.2	6,910		110	62.4	7,120*	64.4	6,600*	66.3	5,480*
130	49.9	6,050	52.2	6,050	54.2	6,050	120		59.4	6,310	61.4	6,150*	63.2	5,090*	
140	45.8	5,310	48.0	5,310	49.9	5,320	130		56.3	5,450	58.3	5,460	60.1	4,690*	
150'	40	80.8	16,220*	-	-	-	-	140	53.0	4,720	55.1	4,730	56.8	4,310*	
	50	77.9	15,410*	80.3	13,300*	-	-	150	49.7	4,100	51.6	4,100	53.3	3,920*	
	60	75.0	14,500*	77.3	12,800*	79.6	10,310*	160	46.1	3,550	48.1	3,550	49.6	3,540*	
	70	72.0	13,690*	74.3	12,280*	76.5	10,040*	170	42.3	3,070	44.2	3,080	45.7	3,080	
	80	68.9	12,520	71.3	11,690*	73.4	9,660*								
	90	65.8	10,530	68.1	10,540	70.2	9,270*								
	100	62.6	8,980	64.9	8,980	67.0	8,810*								
	110	59.3	7,730	61.6	7,730	63.6	7,730								
	120	55.9	6,700	58.1	6,700	60.1	6,700								
	130	52.3	5,840	54.5	5,840	56.4	5,850								
140	48.5	5,110	50.7	5,110	52.5	5,120									
150	44.5	4,490	46.7	4,490	48.4	4,490									



LOAD CHART

HC 80

With 47HI Boom, #9HL Jib

58,100 lb				360°				ANSI B 30.5								
60' Jib length																
Boom length	Jib Radius (Feet)	5.0 Deg offset Boom Angle	5.0 Deg offset Rating (Pounds)	15.0 Deg offset Boom Angle	15.0 Deg offset Rating (Pounds)	25.0 Deg offset Boom Angle	25.0 Deg offset Rating (Pounds)	Boom length	Jib Radius (Feet)	5.0 Deg offset Boom Angle	5.0 Deg offset Rating (Pounds)	15.0 Deg offset Boom Angle	15.0 Deg offset Rating (Pounds)	25.0 Deg offset Boom Angle	25.0 Deg offset Rating (Pounds)	
150'	42	80.9	15,150*	-	-	-	-	170'	45	81.0	10,920*	-	-	-	-	
	50	78.7	14,500*	-	-	-	-		50	79.7	10,520*	-	-	-	-	
	60	75.9	13,720*	78.7	11,780*	-	-		60	77.2	9,830*	79.7	8,510*	-	-	
	70	73.1	12,920*	75.8	11,350*	78.3	8,990*		70	74.6	9,130*	77.1	8,060*	79.4	6,380*	
	80	70.2	12,170*	72.9	10,860*	75.4	8,750*		80	72.0	8,500*	74.5	7,580*	76.8	6,110*	
	90	67.3	10,580	69.9	10,340*	72.4	8,460*		90	69.4	7,880*	71.8	7,140*	74.1	5,780*	
	100	64.3	9,010	66.9	9,020	69.3	8,120*		100	66.6	7,300*	69.1	6,660*	71.3	5,440*	
	110	61.2	7,760	63.8	7,760	66.1	7,740*		110	63.9	6,780*	66.3	6,210*	68.5	5,090*	
	120	58.0	6,730	60.6	6,730	62.9	6,740		120	61.1	6,270*	63.4	5,780*	65.6	4,740*	
	130	54.6	5,870	57.2	5,870	59.4	5,880		130	58.1	5,490	60.5	5,370*	62.6	4,390*	
	140	51.2	5,140	53.7	5,150	55.9	5,150		140	55.1	4,750	57.5	4,700	59.5	4,060*	
	150	47.5	4,520	50.0	4,520	52.1	4,520		150	52.0	4,130	54.3	4,130	56.3	3,710*	
		44	80.8	12,820*	-	-	-		-	160	48.7	3,580	51.0	3,580	52.9	3,380*
		50	79.3	12,400*	-	-	-		-	170	45.2	3,100	47.5	3,110	49.3	3,040*
		60	76.6	11,610*	79.2	10,040*	-		-							
	70	73.9	10,890*	76.5	9,560*	78.9	7,600*									
	80	71.1	10,220*	73.7	9,090*	76.1	7,340*									
	90	68.4	9,570*	70.9	8,630*	73.3	7,020*									
160'	100	65.5	8,830	68.0	8,130*	70.4	6,680*									
	110	62.6	7,580	65.1	7,580	67.4	6,310*									
	120	59.6	6,540	62.1	6,550	64.3	5,960*									
	130	56.5	5,680	58.9	5,690	61.1	5,600*									
	140	53.3	4,950	55.7	4,960	57.8	4,960									
	150	49.9	4,330	52.3	4,330	54.3	4,330									
	160	46.3	3,790	48.7	3,790	50.6	3,800									

NOTES TO LIFTING CAPACITY

HC 80

Jib Chart Information, #9HL

#9HL Jib Composition Chart

Jib length (feet)	20' Inner	10' Center	20' Center	20' Outer	Eff. jib weight (pounds)
40	1	0	0	1	1.850
50	1	1	0	1	2.350
60	1	0	1	1	2.750

47 HI Boom Maximum Boom & Jib Self-Erection Data		
	Boom length (feet)	Jib length (feet)
Blocked Over the End & Over the Side	200	0
	170	60

Load Hoisting Information – 7/8 Inch Diameter EIPS Wire Rope			
Maximum Lifting Capacity (lb)	Minimum Parts of line	Maximum hoisting distance (feet)	
		Main hoist	Auxiliary hoist
22,550	1	588	588

RANGE DIAGRAM

HC 80

46HI Boom, #9 Angle Jib

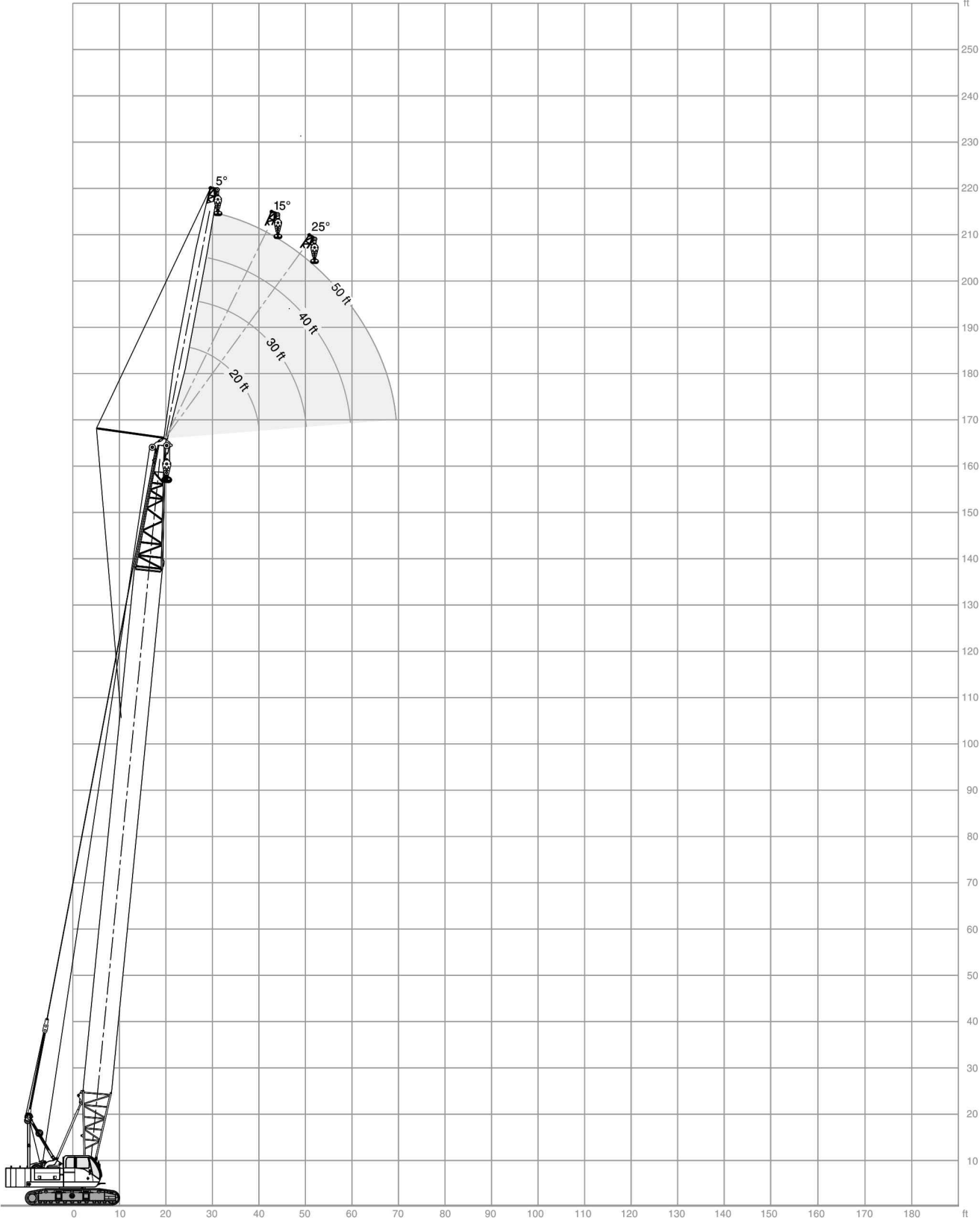

LOAD CHART

HC 80

With 46HI Boom, #9 Angle Jib

58,100 lb		360°				ANSI B 30.5									
20' Jib length															
Boom length	Jib Radius (Feet)	5.0 Deg offset Boom Angle	5.0 Deg offset Rating (Pounds)	15.0 Deg offset Boom Angle	15.0 Deg offset Rating (Pounds)	25.0 Deg offset Boom Angle	25.0 Deg offset Rating (Pounds)	Boom length	Jib Radius (Feet)	5.0 Deg offset Boom Angle	5.0 Deg offset Rating (Pounds)	15.0 Deg offset Boom Angle	15.0 Deg offset Rating (Pounds)	25.0 Deg offset Boom Angle	25.0 Deg offset Rating (Pounds)
50'	17	80.7	18,250*	-	-	-	-	110'	26	81.0	18,250*	-	-	-	-
	20	78.2	18,250*	80.9	18,250*	-	-		30	79.2	18,250*	80.7	18,250*	-	-
	25	74.1	18,250*	76.7	18,250*	79.2	18,250*		35	77.0	18,250*	78.4	18,250*	79.8	18,250*
	30	69.8	18,250*	72.5	18,250*	74.9	18,250*		40	74.7	18,250*	76.2	18,250*	77.5	18,250*
	35	65.5	18,250*	68.1	18,250*	70.5	18,250*		50	70.2	18,250*	71.6	18,250*	72.9	18,250*
	40	60.9	18,250*	63.5	18,250*	65.8	18,250*		60	65.4	18,250*	66.8	18,250*	68.1	18,250*
50	51.1	18,250*	53.6	18,250*	55.7	18,250*	70	60.5	15,100	61.9	15,100	63.1	15,100		
60'	19	80.4	18,250*	-	-	-	-	80	55.3	12,500	56.7	12,500	57.8	12,500	
	20	79.7	18,250*	-	-	-	-	90	49.8	10,520	51.1	10,520	52.2	10,520	
	25	76.1	18,250*	78.4	18,250*	80.6	18,250*	100	43.7	8,960	45.0	8,970	46.0	8,970	
	30	72.4	18,250*	74.7	18,250*	76.9	18,250*	110	36.9	7,720	38.1	7,720	38.9	7,720	
	35	68.7	18,250*	71.0	18,250*	73.1	18,250*	120'	28	80.8	18,250*	-	-	-	-
	40	64.8	18,250*	67.1	18,250*	69.1	18,250*		30	80.0	18,250*	-	-	-	-
50	56.7	18,250*	58.9	18,250*	60.8	18,250*	35		77.9	18,250*	79.3	18,250*	80.5	18,250*	
60	47.6	18,250*	49.7	18,250*	51.5	18,250*	40		75.8	18,250*	77.2	18,250*	78.4	18,250*	
70'	20	80.8	18,250*	-	-	-	-		50	71.6	18,250*	72.9	18,250*	74.1	18,250*
	25	77.6	18,250*	79.7	18,250*	-	-		60	67.3	18,250*	68.6	18,250*	69.7	18,250*
	30	74.4	18,250*	76.5	18,250*	78.4	18,250*	70	62.8	14,890	64.1	14,890	65.2	14,900	
	35	71.1	18,250*	73.2	18,250*	75.1	18,250*	80	58.1	12,290	59.4	12,290	60.4	12,290	
	40	67.7	18,250*	69.8	18,250*	71.6	18,250*	90	53.2	10,310	54.4	10,310	55.4	10,310	
	50	60.7	18,250*	62.7	18,250*	64.5	18,250*	100	47.9	8,750	49.1	8,750	50.0	8,760	
80'	60	53.2	18,250*	55.1	18,250*	56.8	18,250*	110	42.1	7,510	43.2	7,510	44.1	7,510	
	70	44.7	16,020	46.6	16,020	48.1	16,020	120	35.5	6,490	36.6	6,490	37.3	6,490	
	22	80.6	18,250*	-	-	-	-	130'	30	80.7	18,250*	-	-	-	-
	25	78.9	18,250*	80.8	18,250*	-	-		35	78.7	18,250*	80.0	18,250*	-	-
	30	76.0	18,250*	77.8	18,250*	79.6	18,250*		40	76.8	18,250*	78.0	18,250*	79.2	18,250*
	35	73.0	18,250*	74.9	18,250*	76.6	18,250*		50	72.9	18,250*	74.1	18,250*	75.2	18,250*
40	70.0	18,250*	71.9	18,250*	73.6	18,000*	60		68.9	18,250*	70.1	18,250*	71.2	18,250*	
50	63.9	18,250*	65.7	18,250*	67.3	18,250*	70		64.7	14,660	65.9	14,660	67.0	14,660	
90'	60	57.3	18,250*	59.1	18,250*	60.6	18,250*	80	60.4	12,060	61.6	12,060	62.7	12,060	
	70	50.3	15,820	52.0	15,820	53.4	15,820	90	56.0	10,070	57.1	10,080	58.1	10,080	
	80	42.3	13,220	44.0	13,220	45.2	13,220	100	51.2	8,520	52.4	8,520	53.3	8,520	
	100'	23	80.9	18,250*	-	-	-	-	110	46.1	7,270	47.3	7,270	48.1	7,270
		25	79.9	18,250*	-	-	-	-	120	40.6	6,230	41.6	6,230	42.4	6,240
		30	77.2	18,250*	79.0	18,250*	80.6	18,250*	130	34.3	5,380	35.3	5,380	35.9	5,390
35		74.6	18,250*	76.3	18,250*	77.9	18,250*	140'	31	80.9	18,250*	-	-	-	-
40		71.9	18,250*	73.6	18,250*	75.1	18,250*		35	79.4	18,250*	80.6	18,250*	-	-
50		66.4	18,250*	68.0	18,250*	69.5	18,250*		40	77.6	18,250*	78.8	18,250*	79.9	18,250*
60	60.6	18,250*	62.2	18,250*	63.6	18,250*	50		74.0	18,250*	75.1	18,250*	76.2	18,250*	
70	54.5	15,570	56.0	15,570	57.4	15,580	60		70.2	18,030	71.4	18,030	72.4	18,030	
80	47.8	12,980	49.3	12,980	50.6	12,980	70		66.4	14,430	67.5	14,430	68.5	14,430	
100'	90	40.3	11,000	41.7	11,000	42.8	11,000	80	62.4	11,820	63.6	11,820	64.5	11,820	
	25	80.7	18,250*	-	-	-	-	90	58.3	9,840	59.4	9,840	60.4	9,840	
	30	78.3	18,250*	79.9	18,250*	-	-	100	54.0	8,290	55.1	8,290	56.0	8,290	
	35	75.9	18,250*	77.5	18,250*	78.9	18,250*	110	49.5	7,030	50.6	7,030	51.4	7,030	
	40	73.4	18,250*	75.0	18,250*	76.4	18,250*	120	44.6	6,000	45.6	6,000	46.4	6,010	
	50	68.4	18,250*	70.0	18,250*	71.3	18,250*	130	39.2	5,150	40.2	5,150	40.9	5,150	
60	63.2	18,250*	64.7	18,250*	66.1	18,250*	140	33.1	4,420	34.1	4,420	34.6	4,420		
70	57.8	15,350	59.3	15,350	60.5	15,350									
80	52.0	12,740	53.4	12,740	54.6	12,740									
90	45.6	10,760	47.0	10,760	48.1	10,760									
100	38.5	9,220	39.8	9,220	40.7	9,220									



LOAD CHART

HC 80

With 46HI Boom, #9 Angle Jib

58,100 lb		360°				ANSI B 30.5			
20' Jib length									
Boom length	Jib Radius (Feet)	5.0 Deg offset Boom Angle	Rating (Pounds)	15.0 Deg offset Boom Angle	Rating (Pounds)	25.0 Deg offset Boom Angle	Rating (Pounds)	5.0 Deg offset Boom Angle	Rating (Pounds)
	33	80.7	18,250*	-	-	-	-		
	35	80.1	18,250*	-	-	-	-		
	40	78.4	18,250*	79.5	18,250*	80.5	18,250*		
	50	74.9	18,250*	76.0	18,250*	77.0	18,250*		
	60	71.4	17,790	72.5	17,790	73.5	17,790		
	70	67.8	14,200	68.9	14,200	69.9	14,200		
150'	80	64.2	11,580	65.2	11,580	66.2	11,590		
	90	60.4	9,600	61.4	9,600	62.3	9,600		
	100	56.4	8,040	57.5	8,040	58.3	8,040		
	110	52.3	6,790	53.3	6,790	54.1	6,790		
	120	47.9	5,760	48.9	5,760	49.7	5,770		
	130	43.2	4,900	44.2	4,900	44.9	4,900		
	140	38.0	4,170	38.9	4,170	39.6	4,180		
	150	32.1	3,550	33.0	3,560	33.5	3,560		
30' Jib length									
Boom length	Jib Radius (Feet)	5.0 Deg offset Boom Angle	Rating (Pounds)	15.0 Deg offset Boom Angle	Rating (Pounds)	25.0 Deg offset Boom Angle	Rating (Pounds)	5.0 Deg offset Boom Angle	Rating (Pounds)
	24	80.8	18,250*	-	-	-	-		
	25	80.3	18,250*	-	-	-	-		
	30	77.7	18,250*	80.3	18,250*	-	-		
	35	75.0	18,250*	77.6	18,250*	80.0	18,250*		
80'	40	72.3	18,250*	74.9	18,250*	77.3	18,250*		
	50	66.8	18,250*	69.3	18,250*	71.6	18,250*		
	60	61.0	18,250*	63.5	18,250*	65.7	18,250*		
	70	54.9	15,910	57.3	15,920	59.4	15,920		
	80	48.2	13,320	50.6	13,320	52.5	13,320		
	26	80.6	18,250*	-	-	-	-		
	30	78.7	18,250*	-	-	-	-		
	35	76.3	18,250*	78.7	18,250*	80.9	18,250*		
	40	73.8	18,250*	76.2	18,250*	78.4	18,250*		
90'	50	68.8	18,250*	71.2	18,250*	73.3	18,250*		
	60	63.6	18,250*	65.9	18,250*	68.0	18,250*		
	70	58.2	15,670	60.4	15,670	62.4	15,670		
	80	52.4	13,060	54.6	13,060	56.4	13,060		
	90	46.0	11,080	48.1	11,080	49.9	11,080		
	27	80.9	18,250*	-	-	-	-		
	30	79.6	18,250*	-	-	-	-		
	35	77.4	18,250*	79.5	18,250*	-	-		
	40	75.1	18,250*	77.3	18,250*	79.3	18,250*		
100'	50	70.5	18,250*	72.7	18,250*	74.7	18,250*		
	60	65.8	18,250*	67.9	18,250*	69.8	18,250*		
	70	60.9	15,430	63.0	15,430	64.8	15,430		
	80	55.7	12,820	57.7	12,820	59.5	12,820		
	90	50.2	10,840	52.2	10,840	53.8	10,840		
	100	44.1	9,290	46.0	9,300	47.6	9,300		
40' Jib length									
Boom length	Jib Radius (Feet)	5.0 Deg offset Boom Angle	Rating (Pounds)	15.0 Deg offset Boom Angle	Rating (Pounds)	25.0 Deg offset Boom Angle	Rating (Pounds)	5.0 Deg offset Boom Angle	Rating (Pounds)
	34	80.9	18,250*	-	-	-	-		
	35	80.6	18,250*	-	-	-	-		
	40	79.0	18,250*	80.1	18,250*	-	-		
	50	75.8	18,250*	76.8	18,250*	77.8	16,580*		
	60	72.5	17,580	73.5	17,580	74.5	15,770*		
	70	69.1	13,990	70.2	13,990	71.1	13,990		
160'	80	65.7	11,380	66.7	11,380	67.6	11,380		
	90	62.2	9,390	63.2	9,400	64.0	9,400		
	100	58.5	7,830	59.5	7,830	60.3	7,840		
	110	54.7	6,580	55.7	6,580	56.5	6,590		
	120	50.7	5,540	51.7	5,540	52.4	5,550		
	130	46.5	4,690	47.4	4,690	48.1	4,690		
	140	41.9	3,950	42.8	3,950	43.5	3,950		
	150	36.9	3,330	37.8	3,330	38.3	3,330		
	160	31.2	2,790	32.0	2,790	32.4	2,790		
50' Jib length									
Boom length	Jib Radius (Feet)	5.0 Deg offset Boom Angle	Rating (Pounds)	15.0 Deg offset Boom Angle	Rating (Pounds)	25.0 Deg offset Boom Angle	Rating (Pounds)	5.0 Deg offset Boom Angle	Rating (Pounds)
	29	80.7	18,250*	-	-	-	-		
	30	80.3	18,250*	-	-	-	-		
	35	78.3	18,250*	80.3	18,250*	-	-		
	40	76.2	18,250*	78.2	18,250*	80.1	18,250*		
110'	50	72.0	18,250*	74.0	18,250*	75.8	18,250*		
	60	67.6	18,250*	69.6	18,250*	71.4	18,250*		
	70	63.1	15,180	65.1	15,180	66.8	15,190		
	80	58.4	12,570	60.4	12,570	62.0	12,580		
	90	53.5	10,590	55.4	10,590	57.0	10,60		
	100	48.2	9,040	50.0	9,050	51.5	9,050		
	110	42.4	7,790	44.2	7,790	45.6	7,790		
	30	81.0	18,250*	-	-	-	-		
	35	79.1	18,250*	81.0	18,250*	-	-		
	40	77.1	18,250*	79.0	18,250*	80.8	18,250*		
	50	73.2	18,250*	75.1	18,250*	76.8	18,250*		
120'	60	69.2	18,250*	71.0	18,250*	72.7	18,250*		
	70	65.0	14,970	66.9	14,970	68.5	14,970		
	80	60.8	12,370	62.6	12,370	64.2	12,370		
	90	56.3	10,380	58.1	10,390	59.6	10,390		
	100	51.5	8,830	53.3	8,830	54.7	8,830		
	110	46.5	7,580	48.2	7,580	49.5	7,580		
	120	40.9	6,540	42.5	6,540	43.8	6,550		
60' Jib length									
Boom length	Jib Radius (Feet)	5.0 Deg offset Boom Angle	Rating (Pounds)	15.0 Deg offset Boom Angle	Rating (Pounds)	25.0 Deg offset Boom Angle	Rating (Pounds)	5.0 Deg offset Boom Angle	Rating (Pounds)
	32	80.8	18,250*	-	-	-	-		
	35	79.7	18,250*	-	-	-	-		
	40	77.9	18,250*	79.7	18,250*	-	-		
	50	74.3	18,250*	76.0	18,250*	77.7	18,250*		
130'	60	70.5	18,250*	72.3	18,250*	73.9	18,250*		
	70	66.7	14,730	68.4	14,730	70.0	14,740		
	80	62.7	12,120	64.4	12,120	66.0	12,120		
	90	58.6	10,140	60.3	10,140	61.8	10,140		
	100	54.3	8,580	56.0	8,580	57.4	8,580		
	110	49.8	7,330	51.4	7,330	52.7	7,330		
	120	44.9	6,300	46.5	6,300	47.7	6,310		
	130	39.5	5,440	41.0	5,440	42.2	5,440		

LOAD CHART

HC 80

With 46HI Boom, #9 Angle Jib

58,100 lb						360°						ANSI B 30.5											
30' Jib length																							
Boom length	Jib Radius (Feet)	5.0 Deg offset Boom Angle	Rating (Pounds)	15.0 Deg offset Boom Angle	Rating (Pounds)	25.0 Deg offset Boom Angle	Rating (Pounds)	Boom length	Jib Radius (Feet)	5.0 Deg offset Boom Angle	Rating (Pounds)	15.0 Deg offset Boom Angle	Rating (Pounds)	25.0 Deg offset Boom Angle	Rating (Pounds)								
	34	80.7	18,250*	-	-	-	-		37	80.8	18,250*	-	-	-	-								
	35	80.3	18,250*	-	-	-	-		40	79.8	18,250*	-	-	-	-								
	40	78.6	18,250*	80.3	18,250*	-	-		50	76.8	18,250*	78.3	17,840*	79.7	14,960*								
	50	75.2	18,250*	76.9	18,250*	78.4	18,250*		60	73.7	17,640	75.2	17,030*	76.5	14,430*								
	60	71.7	18,090	73.4	18,090	74.9	18,090		70	70.5	14,050	72.0	14,050	73.3	13,770*								
	70	68.1	14,500	69.8	14,500	71.2	14,500		80	67.3	11,430	68.8	11,430	70.1	11,440								
140'	80	64.5	11,880	66.1	11,880	67.5	11,890	160'	90	64.0	9,450	65.4	9,450	66.7	9,450								
	90	60.7	9,900	62.3	9,900	63.7	9,900			100	60.6	7,890	62.0	7,890	63.3	7,890							
	100	56.7	8,350	58.3	8,350	59.6	8,350		110	57.1	6,640	58.5	6,640	59.7	6,640								
	110	52.6	7,090	54.1	7,090	55.4	7,090		120	53.4	5,600	54.8	5,600	55.9	5,600								
	120	48.2	6,060	49.7	6,060	50.9	6,070		130	49.5	4,740	50.9	4,740	52.0	4,740								
	130	43.5	5,210	44.9	5,210	46.1	5,210		140	45.4	4,010	46.7	4,010	47.8	4,010								
	140	38.3	4,470	39.7	4,480	40.7	4,480		150	41.0	3,380	42.3	3,380	43.2	3,380								
									160	36.1	2,840	37.3	2,850	38.2	2,850								
	35	80.9	18,250*	-	-	-	-																
	40	79.3	18,250*	80.9	18,250*	-	-																
	50	76.0	18,250*	77.6	18,250*	79.1	17,490*																
	60	72.8	17,860	74.3	17,860	75.7	16,980*																
	70	69.4	14,260	70.9	14,260	72.3	14,260																
	80	66.0	11,650	67.5	11,650	68.9	11,650																
150'	90	62.4	9,660	63.9	9,670	65.3	9,670																
	100	58.8	8,100	60.3	8,100	61.6	8,110																
	110	55.0	6,850	56.5	6,850	57.7	6,860																
	120	51.0	5,810	52.4	5,810	53.6	5,820																
	130	46.8	4,960	48.2	4,960	49.3	4,960																
	140	42.2	4,220	43.5	4,220	44.6	4,230																
	150	37.2	3,600	38.5	3,600	39.4	3,600																
40' Jib length																							
Boom length	Jib Radius (Feet)	5.0 Deg offset Boom Angle	Rating (Pounds)	15.0 Deg offset Boom Angle	Rating (Pounds)	25.0 Deg offset Boom Angle	Rating (Pounds)	Boom length	Jib Radius (Feet)	5.0 Deg offset Boom Angle	Rating (Pounds)	15.0 Deg offset Boom Angle	Rating (Pounds)	25.0 Deg offset Boom Angle	Rating (Pounds)								
	30	80.7	18,250*	-	-	-	-		33	80.8	18,250*	-	-	-	-								
	35	78.6	18,250*	-	-	-	-		35	80.1	18,250*	-	-	-	-								
	40	76.5	18,250*	79.3	18,250*	-	-		40	78.2	18,250*	80.6	18,250*	-	-								
	50	72.3	18,250*	75.0	17,790*	77.5	16,310*		50	74.6	18,250*	76.9	18,220*	79.1	16,560*								
100'	60	68.0	18,250*	70.6	16,840*	73.1	15,650*	120'	60	70.8	18,250*	73.2	17,310*	75.3	15,890*								
	70	63.5	15,480	66.1	15,490	68.5	15,060*			70	67.0	15,020	69.3	15,020	71.4	15,030							
	80	58.8	12,880	61.4	12,880	63.7	12,890		80	63.1	12,410	65.3	12,410	67.4	12,410								
	90	53.9	10,900	56.4	10,900	58.6	10,910		90	58.9	10,430	61.2	10,430	63.2	10,430								
	100	48.6	9,340	51.0	9,350	53.1	9,350		100	54.6	8,870	56.9	8,870	58.8	8,870								
									110	50.1	7,620	52.3	7,620	54.1	7,620								
									120	45.2	6,590	47.3	6,590	49.0	6,600								
	31	80.9	18,250*	-	-	-	-																
	35	79.4	18,250*	-	-	-	-																
	40	77.4	18,250*	80.0	18,250*	-	-																
	50	73.5	18,250*	76.0	17,950*	78.4	16,410*																
110'	60	69.5	18,250*	72.0	17,070*	74.3	15,760*																
	70	65.4	15,240	67.8	15,240	70.1	15,200*																
	80	61.1	12,630	63.5	12,630	65.7	12,630																
	90	56.6	10,640	59.0	10,650	61.1	10,650																
	100	51.9	9,090	54.2	9,090	56.2	9,090																
	110	46.8	7,840	49.1	7,840	51.0	7,840																
	34	81.0	18,250*	-	-	-	-																
	35	80.6	18,250*	-	-	-	-																
	40	78.9	18,250*	-	-	-	-																
	50	75.5	18,250*	77.7	18,250*	79.8	16,640*																
130'	60	72.0	18,250*	74.2	17,560*	76.3	16,060*																
	70	68.4	14,780	70.6	14,780	72.6	14,780																
	80	64.8	12,160	66.9	12,160	68.9	12,170																
	90	61.0	10,180	63.1	10,180	65.0	10,190																
	100	57.0	8,630	59.1	8,630	61.0	8,630																
	110	52.9	7,370	54.9	7,370	56.7	7,380																
	120	48.5	6,340	50.5	6,340	52.2	6,350																
	130	43.8	5,480	45.7	5,480	47.3	5,480																



LOAD CHART

HC 80

With 46HI Boom, #9 Angle Jib

58,100 lb		360°				ANSI B 30.5									
40' Jib length															
Boom length	Jib Radius (Feet)	5.0 Deg offset Boom Angle	5.0 Deg offset Rating (Pounds)	15.0 Deg offset Boom Angle	15.0 Deg offset Rating (Pounds)	25.0 Deg offset Boom Angle	25.0 Deg offset Rating (Pounds)	Boom length	Jib Radius (Feet)	5.0 Deg offset Boom Angle	5.0 Deg offset Rating (Pounds)	15.0 Deg offset Boom Angle	15.0 Deg offset Rating (Pounds)	25.0 Deg offset Boom Angle	25.0 Deg offset Rating (Pounds)
140'	36	80.8	18,250*	-	-	-	-	160'	39	80.9	18,250*	-	-	-	-
	40	79.6	18,250*	-	-	-	-		40	80.6	18,250*	-	-	-	-
	50	76.3	18,250*	78.4	18,250*	80.4	16,720*		50	77.7	18,250*	79.6	16,450*	-	-
	60	73.0	18,140	75.1	17,770*	77.1	16,160*		60	74.8	17,480*	76.6	15,780*	78.4	12,960*
	70	69.7	14,540	71.7	14,540	73.6	14,550		70	71.8	14,090	73.6	14,090	75.4	12,510*
	80	66.2	11,930	68.3	11,930	70.1	11,930		80	68.7	11,480	70.6	11,480	72.3	11,480
	90	62.7	9,940	64.7	9,950	66.5	9,950		90	65.6	9,480	67.5	9,480	69.1	9,490
	100	59.1	8,390	61.1	8,390	62.8	8,400		100	62.4	7,930	64.3	7,930	65.9	7,930
	110	55.3	7,130	57.2	7,130	58.9	7,140		110	59.2	6,670	61.0	6,670	62.5	6,670
	120	51.3	6,100	53.2	6,110	54.8	6,110		120	55.7	5,640	57.5	5,640	59.0	5,640
130	47.0	5,250	48.9	5,250	50.5	5,250	130	52.2	4,770	53.9	4,770	55.4	4,770		
140	42.5	4,510	44.3	4,510	45.7	4,520	140	48.4	4,040	50.2	4,040	51.6	4,050		
150'	38	80.7	18,250*	-	-	-	-	150	44.5	3,410	46.1	3,420	47.5	3,420	
	40	80.1	18,250*	-	-	-	-	160	40.2	2,870	41.8	2,870	43.0	2,880	
	50	77.0	18,250*	79.0	18,250*	80.9	15,440*								
	60	73.9	17,900	75.9	17,900*	77.8	15,190*								
	70	70.8	14,310	72.7	14,310	74.6	14,310								
	80	67.6	11,690	69.5	11,690	71.3	11,700								
	90	64.3	9,710	66.2	9,710	67.9	9,710								
	100	60.9	8,150	62.8	8,150	64.4	8,150								
	110	57.3	6,890	59.2	6,890	60.8	6,890								
	120	53.7	5,860	55.5	5,860	57.1	5,860								
130	49.8	5,000	51.6	5,000	53.1	5,000									
140	45.7	4,260	47.5	4,260	48.9	4,270									
150	41.3	3,640	43.0	3,640	44.3	3,640									
50' Jib length															
Boom length	Jib Radius (Feet)	5.0 Deg offset Boom Angle	5.0 Deg offset Rating (Pounds)	15.0 Deg offset Boom Angle	15.0 Deg offset Rating (Pounds)	25.0 Deg offset Boom Angle	25.0 Deg offset Rating (Pounds)	Boom length	Jib Radius (Feet)	5.0 Deg offset Boom Angle	5.0 Deg offset Rating (Pounds)	15.0 Deg offset Boom Angle	15.0 Deg offset Rating (Pounds)	25.0 Deg offset Boom Angle	25.0 Deg offset Rating (Pounds)
130'	37	80.8	18,250*	-	-	-	-	150'	40	80.9	18,250*	-	-	-	-
	40	79.8	18,200*	-	-	-	-		50	77.9	17,430*	80.3	14,980*	-	-
	50	76.6	16,970*	79.2	14,740*	-	-		60	75.0	16,350*	77.4	14,280*	79.6	12,730*
	60	73.3	15,830*	75.9	13,950*	78.4	12,580*		70	72.0	14,330	74.4	13,580*	76.6	12,230*
	70	69.9	14,810	72.5	13,290*	75.0	12,040*		80	69.0	11,720	71.3	11,720	73.5	11,720
	80	66.5	12,200	69.1	12,200	71.5	11,630*		90	65.9	9,730	68.2	9,730	70.3	9,740
	90	63.0	10,210	65.5	10,220	67.8	10,220		100	62.7	8,170	65.0	8,170	67.0	8,180
	100	59.3	8,650	61.9	8,650	64.1	8,660		110	59.4	6,920	61.7	6,920	63.7	6,920
	110	55.5	7,400	58.0	7,400	60.2	7,410		120	56.0	5,880	58.2	5,880	60.2	5,880
	120	51.5	6,360	54.0	6,370	56.1	6,370		130	52.4	5,020	54.6	5,020	56.5	5,020
130	47.3	5,510	49.7	5,510	51.7	5,510	140	48.7	4,290	50.8	4,290	52.7	4,300		
140'	38	81.0	18,250*	-	-	-	-	160'	42	80.7	18,250*	-	-	-	-
	40	80.4	18,250*	-	-	-	-		50	78.5	17,480*	80.8	14,960*	-	-
	50	77.3	17,190*	79.8	14,830*	-	-		60	75.7	16,500*	78.0	14,360*	80.1	11,540*
	60	74.2	16,110*	76.7	14,110*	79.0	12,630*		70	72.9	14,120	75.1	13,740*	77.2	11,230*
	70	71.0	14,580	73.5	13,440*	75.8	12,150*		80	70.0	11,500	72.3	11,500	74.3	10,820*
	80	67.8	11,960	70.3	11,960	72.5	11,760*		90	67.1	9,510	69.3	9,510	71.3	9,510
	90	64.5	9,980	66.9	9,980	69.1	9,980		100	64.1	7,950	66.3	7,960	68.3	7,960
	100	61.1	8,420	63.5	8,420	65.7	8,420		110	61.0	6,690	63.2	6,690	65.1	6,700
	110	57.6	7,170	60.0	7,170	62.0	7,170		120	57.8	5,660	60.0	5,660	61.8	5,670
	120	53.9	6,130	56.3	6,130	58.3	6,130		130	54.5	4,800	56.6	4,800	58.5	4,810
130	50.1	5,270	52.3	5,270	54.3	5,270	140	51.1	4,060	53.1	4,060	54.9	4,070		
140	45.9	4,540	48.2	4,540	50.0	4,550	150	47.4	3,430	49.5	3,440	51.2	3,440		
								160	43.5	2,890	45.5	2,890	47.1	2,900	

NOTES TO LIFTING CAPACITY

Jib Chart Information, #9

#9 Jib Composition Chart

Jib length (feet)	10' Inner	10' Center	10' Outer	Eff. jib weight (pounds)
20	1	0	1	1.550
30	1	1	1	2.100
40	1	2	1	2.800
50	1	3	1	3.600

46 HI Boom Maximum Boom & Jib Self-Erection Data		
Over-the-End & Over-the-Side		
Jib	Boom length (feet)	Jib length (feet)
#9	160	50

Load Hoisting Information – 7/8 Inch Diameter EIPS Wire Rope			
Maximum Lifting Capacity (lb)	Minimum Parts of line	Maximum hoisting distance (feet)	
		Main hoist	Auxiliary hoist
18.250	1	588	588

A large rectangular area with horizontal lines, intended for writing notes. The lines are evenly spaced and cover the majority of the page's width and height.

Hydraulic Crawler Crane

Maximum lifting capacity

80 tons.

Boom systems

47HI Boom with Offset Tip

- 200 ft maximum boom length.
- 230 ft maximum boom and jib combination length.
- 47 HI Tubular chord boom, pin connected.
- 20 ft inner and 20 ft outer and 10 ft / 20 ft / 30 ft available inserts provide boom compositions in 10 ft increments from 40 ft to 200 ft.

46HI Angle Boom with 4 Sheave Tip

- 160 ft maximum boom length.
- 200 ft maximum boom and jib combination length.
- 46 HR Angle Boom, pin connected.
- 20 ft inner and 20 ft outer and 10 ft / 20 ft / 40 ft available inserts provide boom compositions in 10 ft increments from 40 ft to 160 ft.

Robust engine

- Cummins QSB 6.7, Tier3, 185 HP @ 2,200 rpm, 6 cylinder, water-cooled, fuel injected diesel with an intercooled, turbo-charger. 60 gallon fuel tank.

Environmental operator's cab

- Designed to provide excellent viewing range and quiet, comfortable operation.
- 37 inch wide cab has wide curve windows on both top and bottom.
- Easy-to-operate modular and ergonomically designed controls reduce operator fatigue and increase productivity.
- Load Moment Indicator with interactive screen features as shockless stop system. Operator can select from three display modes: loaded condition diagram, rated lifting curve or rated lifting load table.
- Adjustable operator's seat, radio, air conditioner, overhead window, sun visor, fan, overhead and front wipers and drum rotation indicators are standard.

Heavy duty carbody and crawlers

- Fabricated steel carbody is deep box constructed with square axles for the crawler side frames. Precision machined top supports anti-friction swing circle and multiple pass hydraulic swivel joint.
- Crawlers have high alloy steel tumbler yokes and rigid fabricated structures with sealed rollers.
- 36" crawler shoes.
- Travel mechanism is set within shoe width.
- Side frames extended or retracted by cylinders inside the carbody.
- Two travel speed settings - 0.8 / 1.24 mph.
- 40 % (22°) gradeability.

Powerful, high-speed hoist system

- Identical inline, independent main and auxiliary load hoisting drums are grooved for 7/8 in. diameter rope. Line speed is 530 fpm, line pull is 32,400 lb.
- Each drum, including optional third, has power up/down and freefall. Load hoists are further controllable in stepless mode.
- Ample work space in front of the drums allows easy access for cable installation and maintenance.
- Internal expanding band clutch.
- 3.3 rpm swing speed.

High capacity, dependable hydraulic system

- Open circuit system has 2 variable displacement piston pumps with system capacity of 116 gpm.
- Hydraulic reservoir with 79 gallons capacity and 10 micron filtration.
- Component working range is between -4 and 203° F.
- Flip up doors provide easy access to engine and hydraulic components for service.

Three piece removable counterweight

- Three piece pin connected counterweight can be assembled or disassembled easily within minutes.
- Hydraulic counterweight removal system is standard and utilizes the „A“ frame and crane auxiliary drum to make the HC 80 one of the most transportable cranes in its class.
- Moves on three trucks with full boom and #9HL jib. Carbody sideframes and boom weigh in at under 88,000 lb. At 11 ft 9.75 in. wide and 10 ft 2 in. high, the HC 80 at working weight will transport on a standard lowboy trailer.

Options include

- Third drum
- Automotive type lights
- Hydraulic power take off
- Jib and jib inserts
- Luffing jib attachment
- Single sheave extension

TRANSPORT EXAMPLE FOR HC 80

HC 80

170' 47HI Boom and 60' #9HL jib

Loads based on 48 ft flatbed trailer. Loading information is an example only, specific loads will vary depending on crane options. Weights shown do **NOT** include blocking or tie-down material.

LOAD NO. 1

3 x 47 H 30' Boom Center Sections @ 2,045 # each	6,135 lb
Inside Counterweight	16,000 lb
#9HL 20' Jib Center	385 lb
Center Counterweight	21,000 lb
1 x 47 H 10' Boom Center Sections	700 lb
TOTAL LOAD	44,220 lb

LOAD NO. 2

Outside Counterweight	21,000 lb
47HI Boom Outer	2,225 lb
47 H 30' Boom Center	2,045 lb
#9HL Jib Inner	890 lb
#9HL Jib Outer	665 lb
Crate, Misc. Parts, Block & Ball	3,500 lb
TOTAL LOAD	30,325 lb

LOAD NO. 3

Basic Upper, including:

a) Carbody	
b) Sideframes	
c) Boom Inner	
TOTAL LOAD (BASIC CRANE, etc.)	88,000 lb

www.terexcranes.com

Effective Date: December 2010.

Product specifications and prices are subject to change without notice or obligation. The photographs and/or drawings in this document are for illustrative purposes only. Refer to the appropriate Operator's Manual for instructions on the proper use of this equipment. Failure to follow the appropriate Operator's Manual when using our equipment or to otherwise act irresponsibly may result in serious injury or death. The only warranty applicable to our equipment is the standard written warranty applicable to the particular product and sale and Terex makes no other warranty, express or implied. Products and services listed may be trademarks, service marks or trade-names of Terex Corporation and/or its subsidiaries in the USA and other countries. All rights are reserved. Terex® is a registered trademark of Terex Corporation in the USA and many other countries.

Copyright 2010 Terex Corporation

Terex Cranes, Global Marketing, Dinglerstraße 24, 66482 Zweibrücken, Germany
Tel. +49 (0) 6332 830, Email: info.cranes@terex.com, www.terexcranes.com

Brochure Reference: TC-DS-I-E-HC80-12/10



WORKS FOR YOU.™