



# MLC650

## Product Guide

ASME B30.5  
Imperial

### Features

- 717 USt capacity
- 772 USt capacity with VPC-MAX<sup>®</sup>
- 27,227 ft-kips maximum load moment
- 65,962 ft-kips maximum load moment with VPC-MAX<sup>®</sup>
- 341.2 ft B10:680 boom
- 479.0 ft B60:680 boom with VPC-MAX<sup>®</sup>
- 137.8 ft No. 148 fixed jib on B10:680 boom
- 331.4 ft LJ:681-682 luffing jib on B10:680 boom

# MANITOWOC MLC650

The MLC650 combines revolutionary VPC® technology with the dynamic Crane Control System (CCS) to deliver class-leading load charts. Ultimate jobsite productivity and versatility ensure outstanding ROI.

## Features

### > Crane Control System

The Crane Control System offers a user-friendly interface, two full graphic displays mounted horizontally for better visibility, a jog dial for easier data input and ergonomic joysticks.

### > Variable Position Counterweight (VPC®)

The Manitowoc MLC650 features a counterweight system that automatically positions the crane's counterweight as required to match lifting demands. Crane lifting capability is optimized by automatic positioning of the counterweight, eliminating the need for carbody counterweight. Additionally, counterweight boxes are designed to be common across multiple crane platforms and will be utilized on Manitowoc Model MLC300 as well as future new models.

### > VPC-MAX®

Capacity and boom and jib combination lengths can be increased through addition of the exclusive VPC-MAX® attachment. The VPC-MAX® attachment utilizes all of the standard VPC® components, and only requires the addition of a 118.1 ft fixed mast and the VPC-MAX® beam. With the VPC-MAX® attachment, the load moment of the MLC650 more than doubles its load. The position of the VPC-MAX® counterweight is automatically positioned based on lifted load, boom length, or boom and jib length and load radius.

### > FACT™ Connectors

Manitowoc's Fast Aligning Connection Technology (FACT™) automatically aligns crane components for fast, easy assembly.



# MLC650 benefits

## Transportation

The MLC650 is designed to be transported globally with optimized component weights and dimensions. The MLC650 features a removable live mast shipping module and boom inserts designed to allow luffing jib inserts to ship within the boom inserts for cost-effective transport.



## Productivity

Revolutionary Variable Position Counterweight (VPC) helps deliver class-leading lift capacities with less counterweight. The system works by automatically moving the counterweight into a maximized position for the given configuration and load case. No commands are necessary, so the operator is free to focus on the load and jobsite.

## Ease of use

The Crane Control System (CCS) features a user-friendly interface with all necessary crane control information within easy view on two display screens. A fully enclosed and insulated galvanized steel cab features power tilt and full-view glass for unmatched visibility.



## What you need, when you need it.

**Get right to work with the right equipment** — Manitowoc Finance gives you access to flexible, affordable financing you can use to seize profitable new opportunities as they arise.

**Feel confident in your investment** — rest easy with the assurance of the world's most advanced crane service and support network.

# Contents

- Outline dimensions ..... 5
- Transport data ..... 12
- Assembly ..... 13
- Performance data..... 15
- Boom combinations ..... 17
- Working range/load charts – Main boom ..... 20
- Working range/load charts – Extended upper boom ..... 22
- Working range/load charts – Luffing jib ..... 24
- Outline dimensions – VPC-MAX® ..... 27
- Transport data – VPC-MAX® ..... 28
- Boom combinations– VPC-MAX® ..... 29
- Working range/load charts – Main boom – VPC-MAX® ..... 32
- Working range/load charts – Extended upper boom ..... 34
- Working range/load charts – Luffing jib – VPC-MAX® ..... 38
- Specifications..... 41

# Outline dimensions

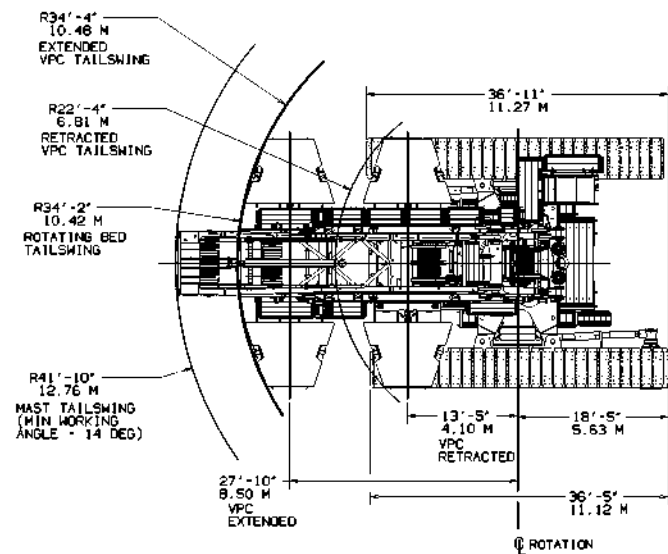
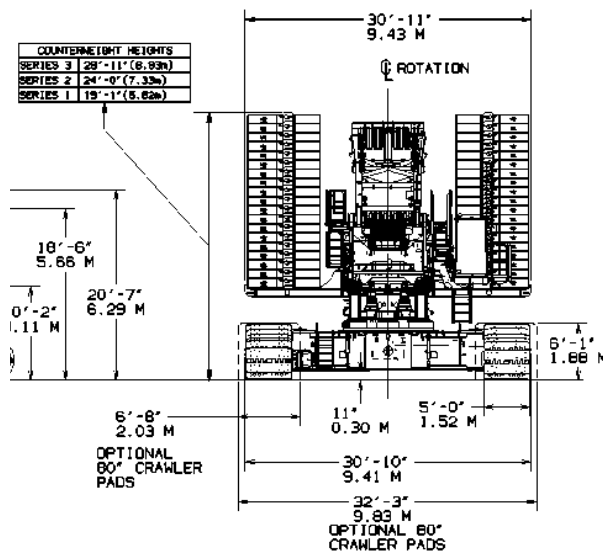
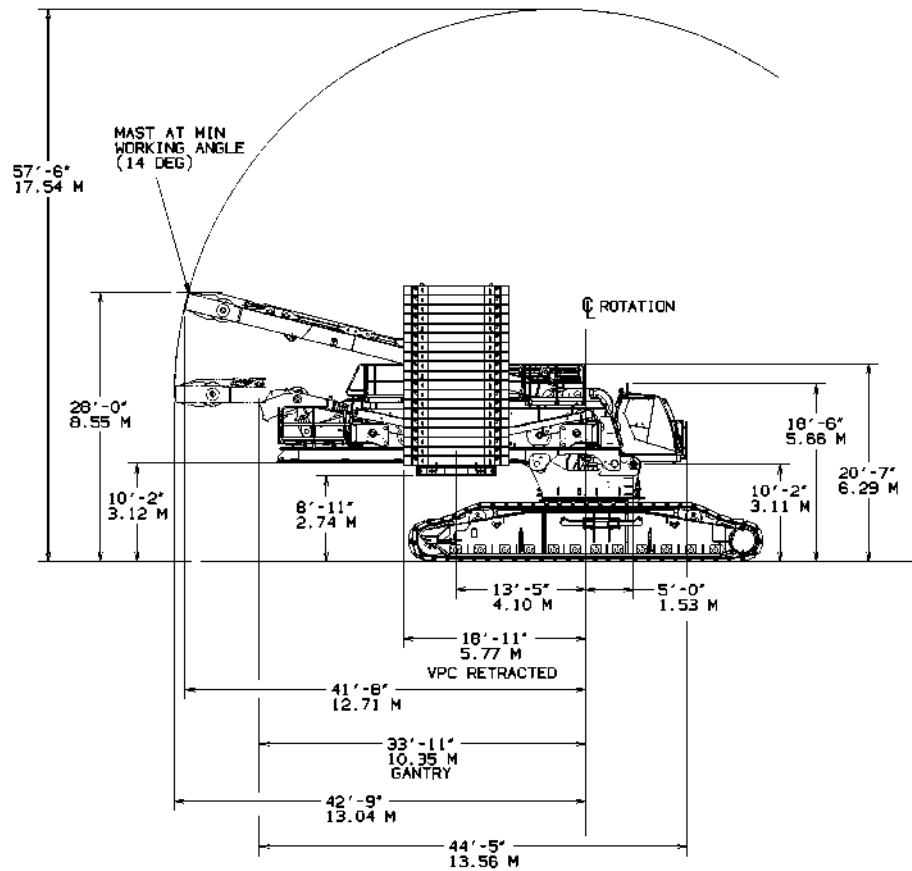

# Outline dimensions

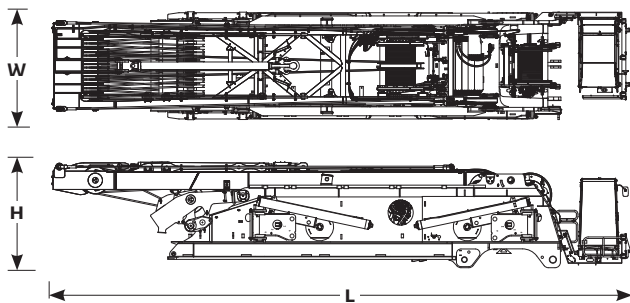

Rotating bed assembly	
Length	52' 10"
Width	9' 10"
Height	9' 10"
Weight	157,900 lb

*Note: includes live mast, boom hoist, gantry, rotating bed jacks, whip hoist.*

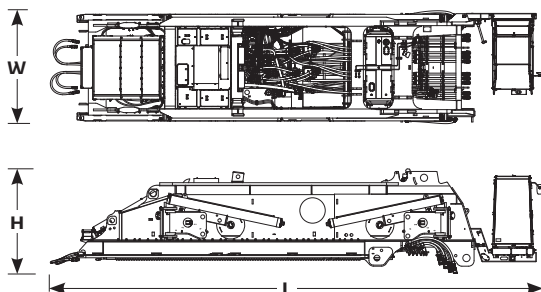

Rotating bed assembly	
Length	42' 4"
Width	9' 10"
Height	8' 6"
Weight	98,300 lb

*Note: includes rotating bed jacks, whip hoist.  
Note: excludes live mast, boom hoist, gantry.*

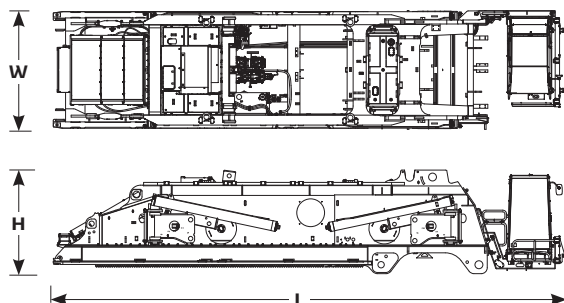

Rotating bed assembly	
Length	42' 4"
Width	9' 10"
Height	8' 6"
Weight	85,800 lb

*Note: includes rotating bed jacks.  
Note: excludes whip hoist, live mast, boom hoist, gantry.*

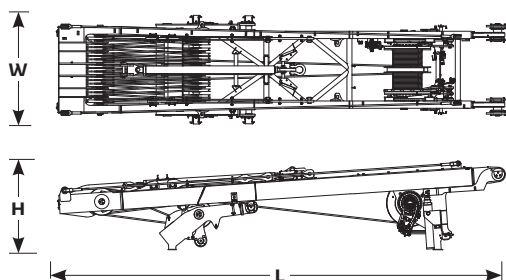

Live mast package	
Length	40' 8"
Width	9' 10"
Height	8' 2"
Weight	59,300 lb

*Note: includes live mast, boom hoist, gantry.*

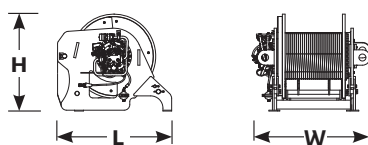

Whip hoist package	
Length	5' 3"
Width	5' 3"
Height	4' 7"
Weight	12,800 lb

*Note: includes wire rope.*

# Outline dimensions

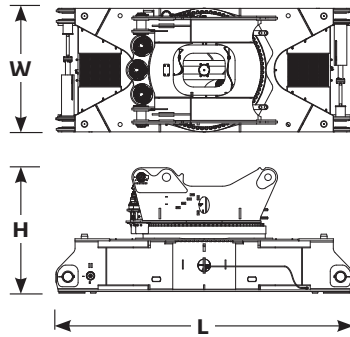

Carbody assembly without jacks	
Length	23' 7"
Width	9' 10"
Height	9' 10"
Weight	91,500 lb

*Note: includes carbody, adapter frame, three swing drives, slewing ring.*

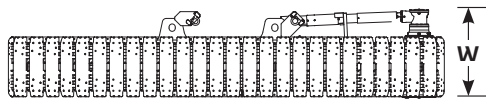

Crawler assembly 80 inch pads	
Length	36' 5"
Width	7' 7"
Height	6' 3"
Weight	85,800 lb

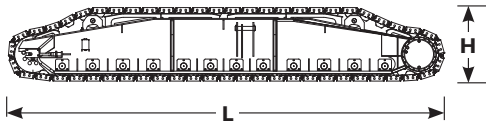

Crawler assembly 80 inch pads	
Weight	103,200 lb

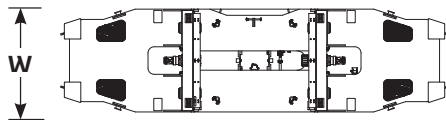

Counterweight tray assembly	
Length	30' 10"
Width	8' 2"
Height	2' 11"
Weight	44,100 lb

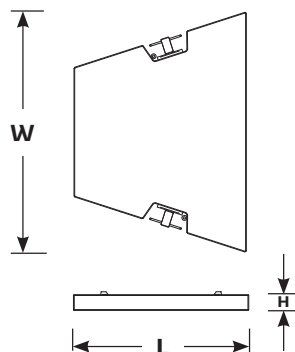
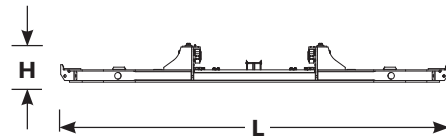

Counterweight box	
Length	7' 10"
Width	10' 10"
Height	1' 4"
Weight	22,000 lb

# Outline dimensions

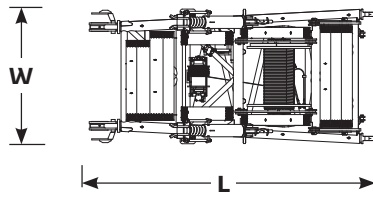

## 19.7 ft No. 680 boom butt

Length	21' 4"
Width	9' 10"
Height	9' 2"
Weight	42,300 lb

*Note: includes main load hoist #1, wire rope, rigging winch.*

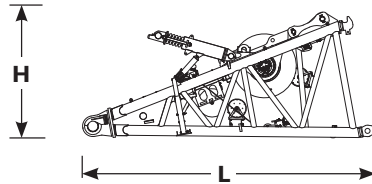

## 19.7 ft No. 680 boom butt with luffing hoist

Weight	57,800 lb
--------	-----------

*Note: includes main load hoist #1, wire rope, rigging winch, luffing hoist.*

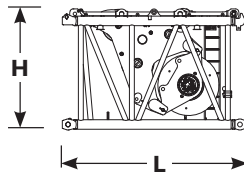

## 13.1 ft No. 680 boom insert

Length	14' 1"
Width	9' 10"
Height	9' 2"
Weight	39,000 lb

*Note: includes main load hoist #2, wire rope and backstay straps.*

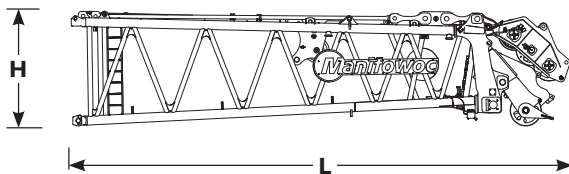

## 32.8 ft No. 680 boom top

Length	40' 0"
Width	9' 10"
Height	9' 2"
Weight	41,400 lb

*Note: includes lower boom points, wire rope guides..*

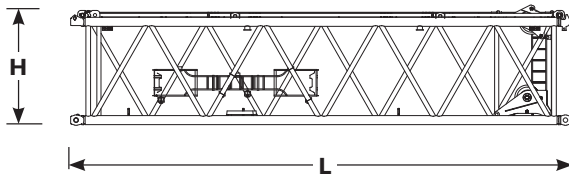

## 39.4 ft No. 680 boom insert, extra heavy with sheaves

Length	40' 0"
Width	9' 10"
Height	9' 2"
Weight	27,800 lb

*Note: includes boom straps, backstay straps, luffing jib wire rope guide.*

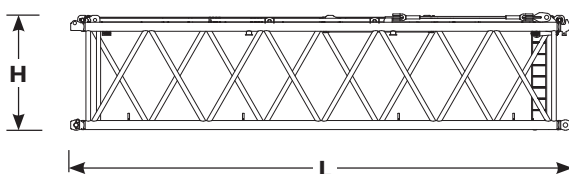

## 39.4 ft No. 680 boom insert, heavy with equalizer

Length	40' 0"
Width	9' 10"
Height	9' 2"
Weight	23,100 lb

*Note: includes boom straps, backstay straps.*



# Outline dimensions

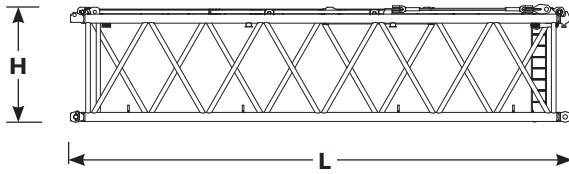

39.4 ft No. 680 boom insert, extra heavy	
Length	40' 0"
Width	9' 10"
Height	9' 2"
Weight	25,600 lb

*Note: includes boom straps, backstay straps.*

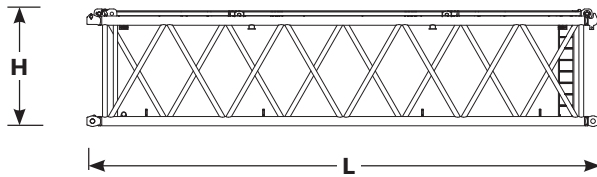

39.4 ft No. 680 boom insert, heavy	
Length	40' 0"
Width	9' 10"
Height	9' 2"
Weight	21,400 lb

*Note: includes boom straps, backstay straps.*

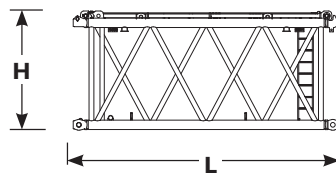

19.7 ft No. 680 boom insert, heavy	
Length	20' 8"
Width	9' 10"
Height	9' 2"
Weight	12,600 lb

*Note: includes boom straps, backstay straps.*

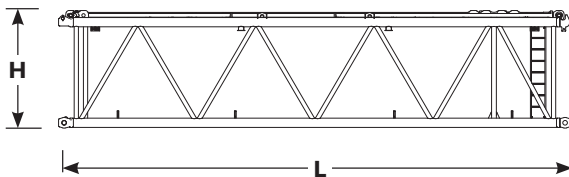

39.4 ft No. 680 boom insert, medium with suspension	
Length	40' 0"
Width	9' 10"
Height	9' 2"
Weight	17,600 lb

*Note: includes boom straps, backstay straps.*

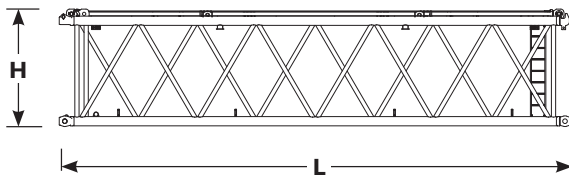

39.4 ft No. 680 boom insert, medium	
Length	40' 0"
Width	9' 10"
Height	9' 2"
Weight	17,400 lb

*Note: includes boom straps, backstay straps.*

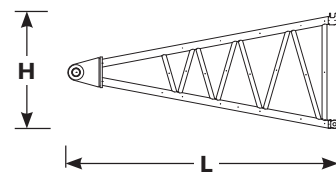

19.7 ft No. 681 luffing jib butt	
Length	20' 12"
Width	9' 10"
Height	8' 10"
Weight	12,600 lb

*Note: includes jib stops.*

# Outline dimensions

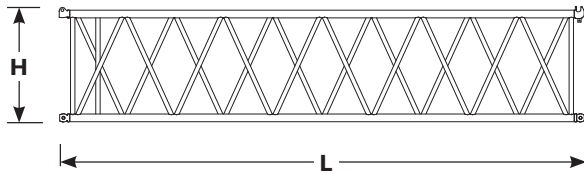

39.4 ft No. 681 luffing jib insert	
Length	40' 4"
Width	9' 10"
Height	9' 2"
Weight	12,600 lb

*Note: includes jib straps.*

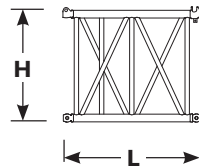

9.8 ft No. 681 luffing jib insert	
Length	10' 6"
Width	9' 10"
Height	9' 2"
Weight	4600 lb

*Note: includes jib straps.*

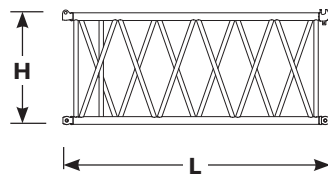

19.7 ft No. 681 luffing jib insert	
Length	20' 8"
Width	9' 10"
Height	9' 2"
Weight	7500 lb

*Note: includes jib straps.*

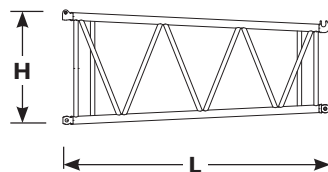

19.7 ft No. 681-682 transition insert	
Length	20' 8"
Width	9' 10"
Height	9' 2"
Weight	9500 lb

*Note: includes jib straps.*

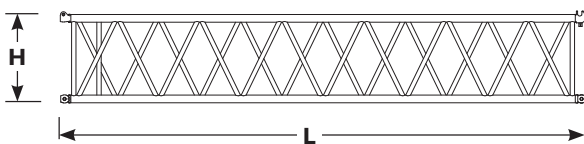

39.4 ft No. 682 luffing jib insert	
Length	20' 4"
Width	8' 2"
Height (max)	8' 2"
Weight	6400 lb

*Note: includes jib straps.*

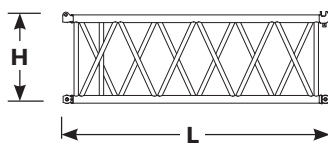

19.7 ft No. 682 luffing jib insert	
Length	20' 4"
Width	8' 2"
Height	8' 2"
Weight	6400 lb

*Note: includes jib straps.*

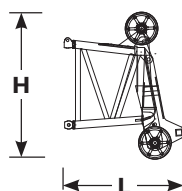

6.7 ft No. 681-682 luffing jib top	
Length	10' 10"
Width	8' 2"
Height (max)	9' 2"
Weight	16,800 lb

*Note: includes (8) sheave pack, wire rope guide.*

# Outline dimensions

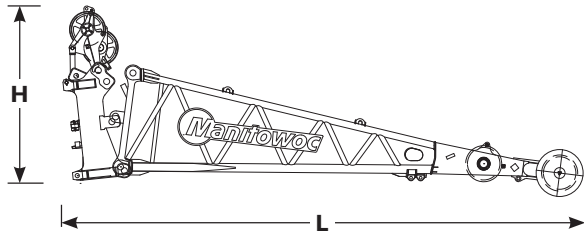

### 3.3 ft No. 682 cap + extended upper boom point

Length	37' 9"
Width	8' 10"
Height (max)	9' 2"
Weight	20,900 lb

*Note: includes 2 sheave lower boom point in wind cap.*

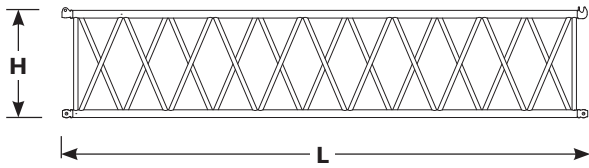

### 39.4 ft No. 684 mast lower mast insert

Length	40' 0"
Width	8' 2"
Height (max)	9' 2"
Weight	13,000 lb

*Note: includes backhitch and counterweight straps.*

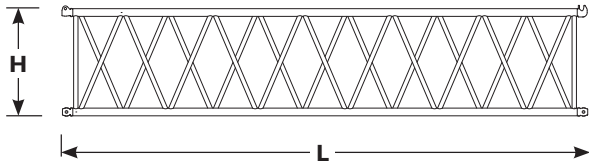

### 39.4 ft No. 684 mast upper mast insert

Length	40' 0"
Width	8' 2"
Height (max)	9' 2"
Weight	13,700 lb

*Note: includes backhitch and counterweight straps.*

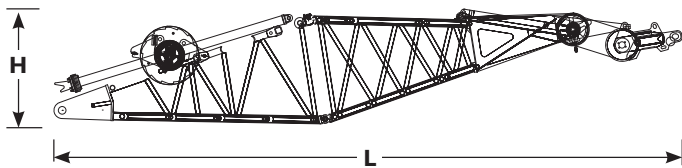

### No. 684 mast top + butt transport package

Length	47' 11"
Width	8' 6"
Height	9' 2"
Weight	54,900 lb

*Note: includes boom hoist drum and equalizer.*

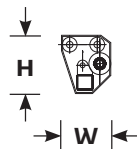

### VPC-MAX actuator assembly

Length	16' 5"
Width	3' 11"
Height	3' 11"
Weight	13,900 lb

### VPC-MAX beam assembly

Length	36' 9"
Width	9' 10"
Height	3' 11"
Weight	47,000 lb

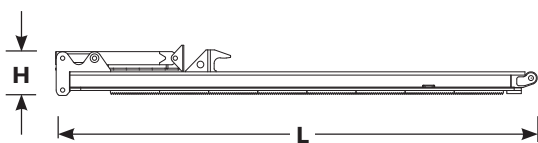

### VPC-MAX aux member assembly

Length	9' 10"
Width	7' 10"
Height	1' 8"
Weight	9,500 lb

# Transport data

Load summary																															
282 ft boom with series 2 counterweight Quantity on trailer load # (Does not include blocking, strapping, etc.)																															
Item	Qty	Weight lb	1	2	3	4	5	6	7	8	9	10	11	12	13	14	15	16	17	18	19	20	21	22	23	24	25	26	27	28	29
Upperworks module	1	85,800	1																												
Whip hoist	1	12,800									1																				
Live mast package	1	59,300	1																												
Carbody + adapter	1	91,500		1																											
Crawler assembly (1,5 m pads)	2	85,800			1	1																									
Counterweight tray	1	44,100					1																								
Counterweight box	28	22,000																2	2	2	2	2	2	2	2	2	2	2	2	2	
Boom butt with drum 1	1	42,300						1																							
13.1 ft No. 680 boom insert with drum 2	1	39,000							1																						
39.4 ft No. 680 extra heavy boom insert with sheaves	1	27,800								1																					
39.4 ft No. 680 extra heavy boom insert	1	25,600									1																				
39.4 ft No. 680 heavy boom insert	1	21,400										1																			
39.4 ft No. 680 heavy boom insert with equalizer rails	1	23,400											1																		
19.7 ft No. 680 heavy boom insert	1	12,600												1																	
39.4 ft No. 680 medium insert with suspension	1	19,600													1																
32.8 ft No. 680 boom top	1	41,400														1															
350 USt block	1	17,400													1																
24.5 USt weight ball	1	2,900											1																		
Approximate total shipping weight lb			85,800	59,300	91,500	85,800	85,800	44,100	42,300	39,000	40,600	25,600	24,300	23,400	30,000	19,600	41,400	44,000	44,000	44,000	44,000	44,000	44,000	44,000	44,000	44,000	44,000	44,000	44,000	44,000	

# Assembly

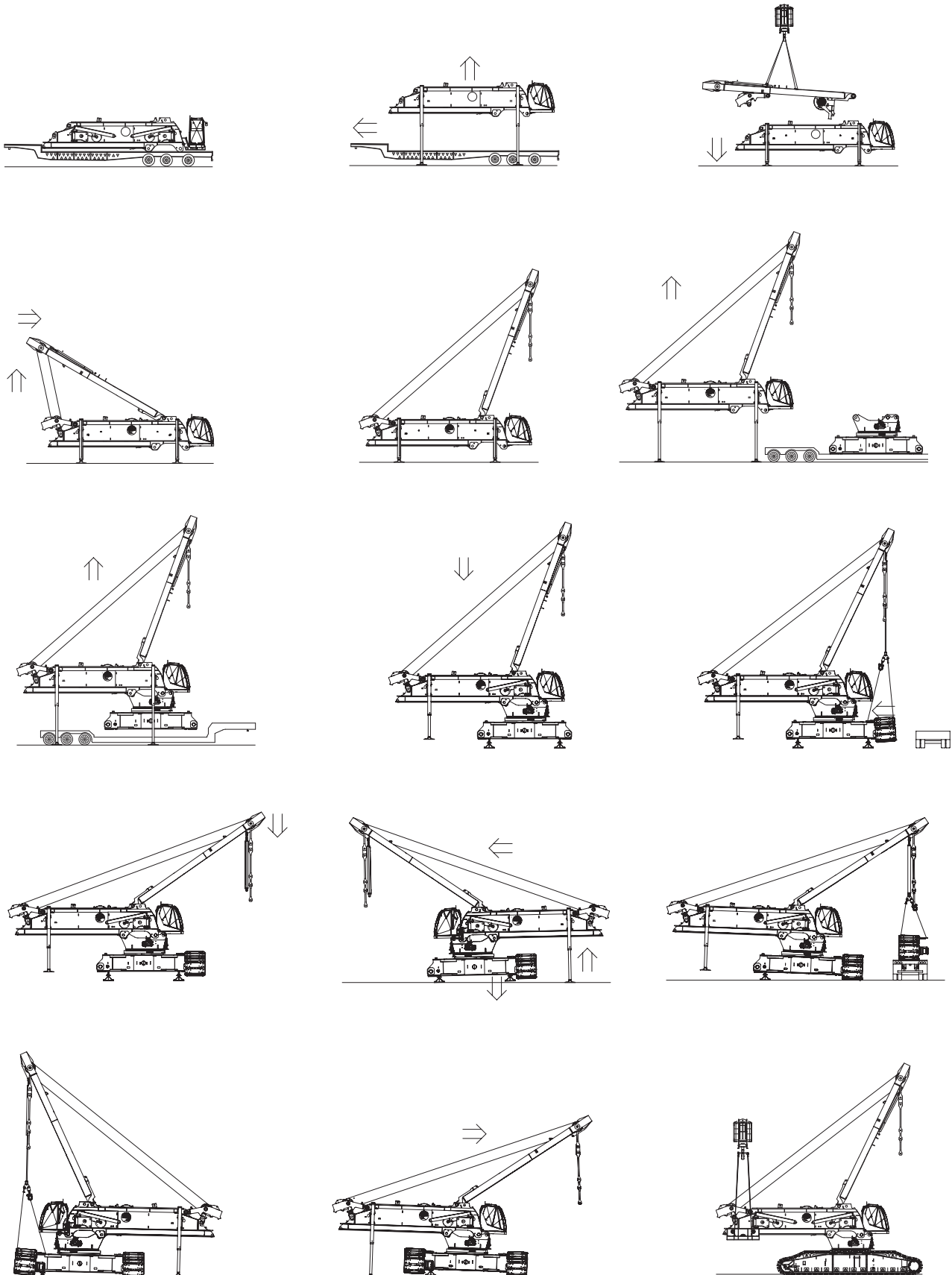

# Assembly

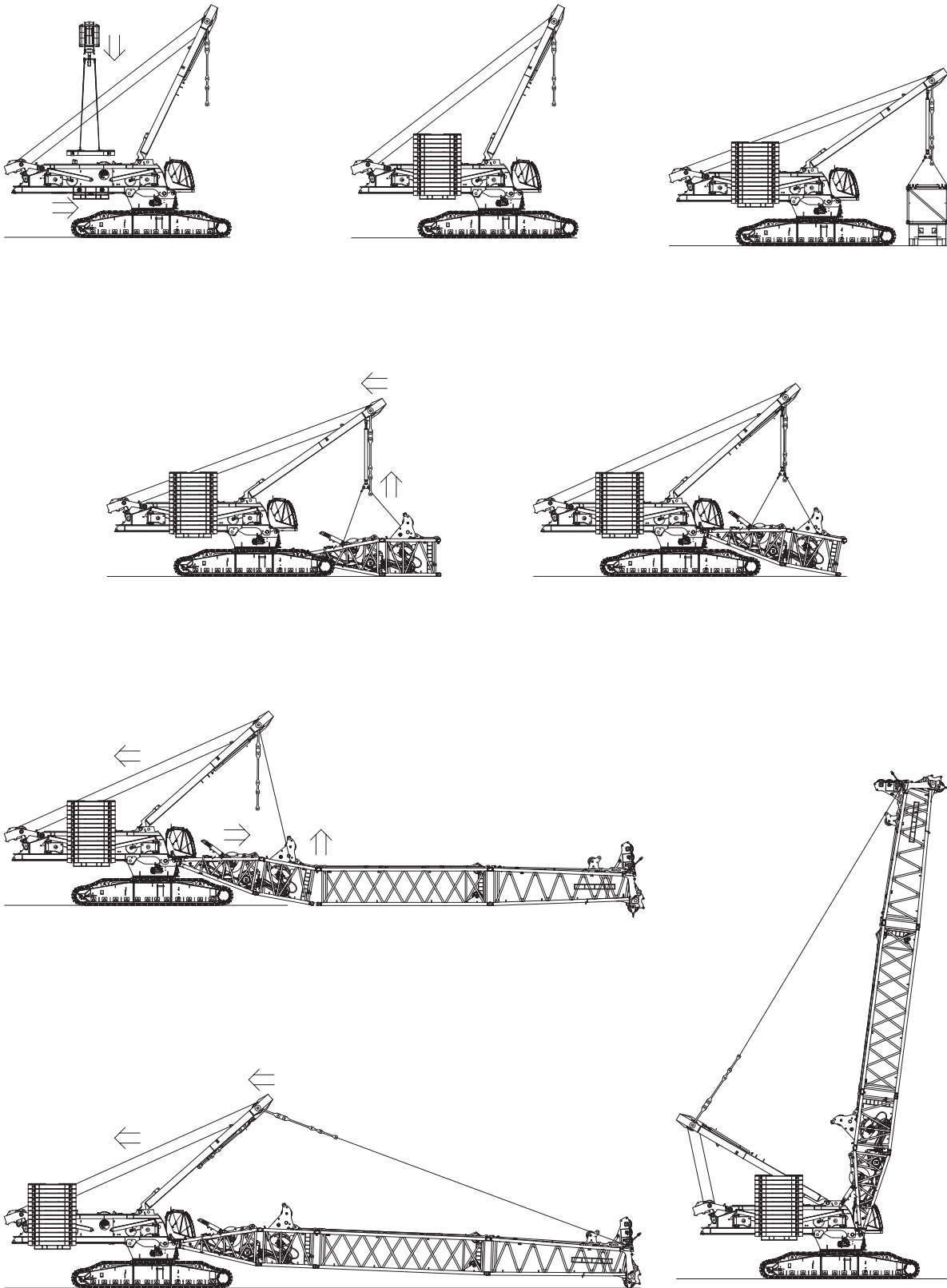

# Performance data

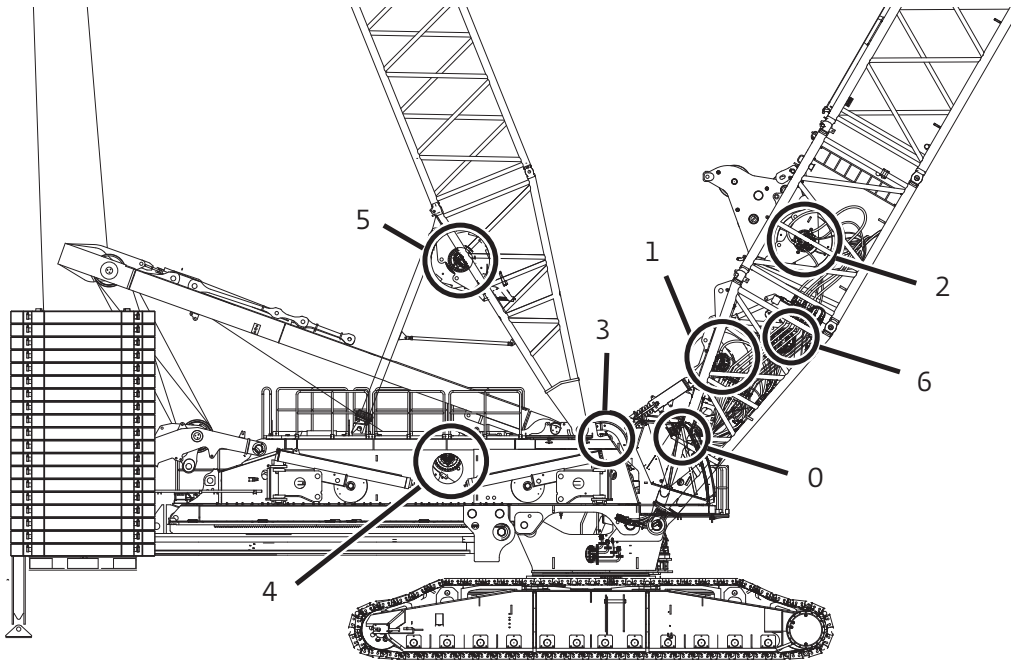

Drum identification	
Drum number	Function
1	Main hoist – standard
2	Auxiliary main hoist – standard
3	Whip hoist – standard
4	Boom hoist (VPC™) – standard mast hoist (VPC-MAX) – standard
5	Boom hoist (VPC-MAX) – standard with VPC-MAX
6	Luffing hoist – standard with luffing jib
0	Rigging winch – standard

Working weight	
105.0 ft No. 680 main boom	1,427,108 lb
upper boom point	
689 USt hook block	
881,800 lb counterweight	

# Performance data

## B10: 680/B60: 680 boom Hoist reeving for main load block single lead line – 32 mm wire rope

No. Parts of Line	Maximum Load lb
2	97,600
4	195,200
6	292,800
8	390,400
10	488,000
12	585,600
14	683,200
16	773,610
18	861,860
20	948,350
22	1,033,110
24	1,116,200
26	1,197,620
28	1,277,430
30	1,355,650

## B10: 680/B60: 680 boom Hoist reeving for main load block two lead lines – 32 mm wire rope

No. Parts of Line	Maximum Load lb
8	390,400
12	585,600
16	780,800
20	976,000
24	1,171,200
28	1,366,400
32	1,543,240

## B10: 680/B60: 680 boom Hoist reeving for whip load block single lead line – 28 mm wire rope

No. Parts of Line	Maximum Load lb
1	30,000
2	60,000

## B40: 680-681-682 B80: 680-681-682 with 25 ft extended upper boom point Hoist reeving for main load block single lead line – 32 mm wire rope

No. Parts of Line	Maximum Load lb
2	97,600
4	195,200
6	292,800
7	341,600

## Maximum spooling capacities

Drum 1 (hoist line) 32 mm wire rope*	3,608 ft 10 layers
Drum 2 (hoist line) 32 mm wire rope*	3,608 ft 10 layers
Drum 3 (whip line) 28 mm wire rope*	1,900 ft 8 layers

\*22 ft is deducted from maximum spooling capacities for 3 dead wraps per drum

## Performance for main hoist (drum #1) and auxiliary main hoist (drum #2) Single line speed in ft per minute

Single line pull lb	Single line pull/single line speed ft/min Layer									
	1	2	3	4	5	6	7	8	9	10
0	308	335	364	394	420	449	476	505	535	561
10000	292	318	344	371	394	420	443	466	492	515
20000	279	302	325	344	367	387	410	430	440	446
28800	266	285	295	299	305	312	315	322	328	331
40000	226	233	240	243	249	256	259	266	276	289
48800	197	203	207	213	220	230	243	253	253	253

## Performance for whip (drum #3) 28 mm wire rope Single line speed in ft per minute

Single line pull lb	Single line pull/single line speed ft/min Layer							
	1	2	3	4	5	6	7	8
0	295	322	348	371	397	420	446	469
5000	282	305	328	351	374	394	417	436
10000	269	292	312	331	348	367	387	404
15000	256	276	292	295	302	305	308	315
20000	226	230	236	240	243	249	253	259
25000	190	197	200	207	210	217	230	240
30000	171	174	177	190	203	213	226	236



# Boom combinations

B10: 680 main boom combinations					
Boom length (ft)	Main boom inserts (ft)				
	13.1 XH No. 680	39.4 XH No. 680	19.7 H No. 680	39.4 H No. 680	39.4 M No. 680
105.0	1	1	0	0	0
124.7	1	1	1	0	0
144.4	1	1	0	1	0
164.0	1	1	1	1	0
183.7	1	2	0	1	0
203.4	1	2	1	1	0
223.1	1	2	0	1	1
242.8	1	2	1	1	1
265.5	1	2	0	2	1
282.2	1	2	1	2	1
301.8	1	2	0	3	1
321.5	1	2	1	3	1
341.2	1	2	0	4	1

*XH: Extra heavy insert*  
*H: Heavy insert*  
*M: Medium insert*

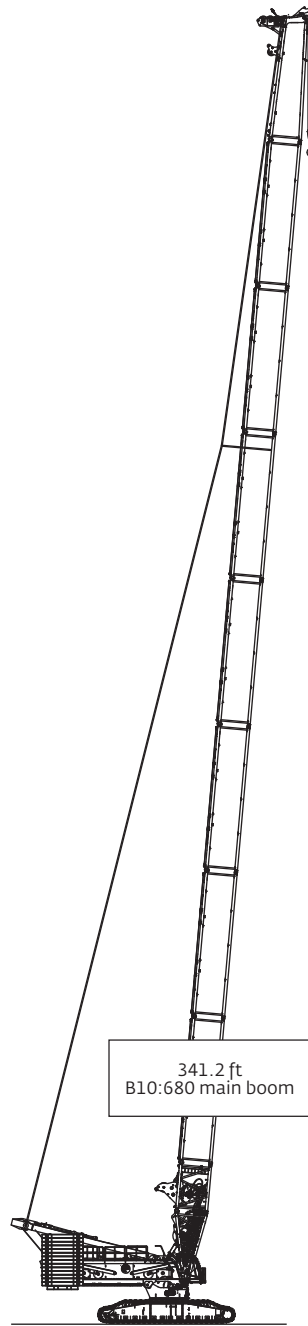

# Boom combinations

## B40: 680-681-682 boom with 25 ft extended upper boom point

Boom length (ft)	Main boom inserts								
	13.1 ft XH No. 680	39.4 ft XH No. 680	39.4 ft H No. 680	39.4 ft M No. 680	19.7 ft No. 680-681	9.8 ft No. 681	19.7 ft No. 681	39.7 ft No. 681	39.7 ft No. 681-682
144.4	1	1	0	0	1	1	0	0	1
164.0	1	1	0	0	1	1	1	0	1
183.7	1	1	0	0	1	1	0	1	1
203.4	1	1	1	0	1	1	1	0	1
223.1	1	2	1	0	1	1	0	0	1
242.8	1	2	1	0	1	1	1	0	1
252.6	1	2	1	1	1	0	0	0	1
262.5	1	2	1	1	1	1	0	0	1
272.3	1	2	1	1	1	1	0	0	1
282.2	1	2	1	1	1	1	1	0	1
292.0	1	2	2	1	1	0	0	0	1
301.8	1	2	2	1	1	1	0	0	1
311.7	1	2	2	1	1	0	1	0	1
321.5	1	2	2	1	1	1	1	0	1
331.4	1	2	2	1	1	0	0	1	1
341.2	1	2	2	1	1	1	0	1	1
351.0	1	2	2	1	1	0	1	1	1
360.9	1	2	2	1	1	1	1	1	1

XH: Extra heavy insert

H: Heavy insert

M: Medium insert

\* luffing jib insert

\*\* luffing jib transition insert

For specific configurations refer to [www.cranelibrary.com](http://www.cranelibrary.com).

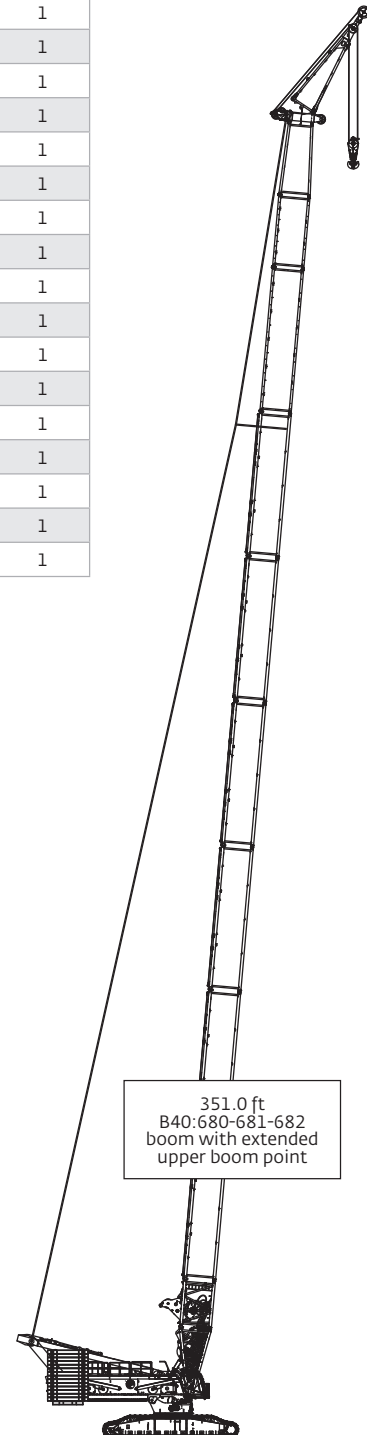

THIS CHART IS ONLY A GUIDE AND SHOULD NOT BE USED TO OPERATE THE CRANE.

The individual crane's load chart, operating instructions and other instructional plates must be read and understood prior to operating the crane

# Boom combinations

Lj: 681-682 luffing jib combinations							
Luffing jib length (ft)	Luffing jib inserts						
	39.4 ft No. 680-681	9.8 ft No. 681	19.7 ft No. 681	39.4 ft No. 681	19.7 ft No. 681-682	19.7 ft No. 682	39.4 ft No. 682
85.3	1	0	0	0	1	0	0
95.1	1	1	0	0	1	0	0
105.0	1	0	1	0	1	0	0
114.8	1	1	1	0	1	0	0
124.7	1	0	0	1	1	0	0
134.5	1	1	0	1	1	0	0
144.4	1	0	1	1	1	0	0
154.2	1	1	1	1	1	0	0
164.0	1	0	1	1	1	1	0
173.9	1	1	1	1	1	1	0
193.6	1	1	1	1	1	0	1
213.3	1	1	1	1	1	1	1
232.9	1	1	1	1	1	0	2
252.6	1	1	1	1	1	1	2
272.3	1	1	1	1	1	0	3
292.0	1	1	1	1	1	1	3
311.7	1	1	1	1	1	0	4
331.4	1	1	1	1	1	1	4

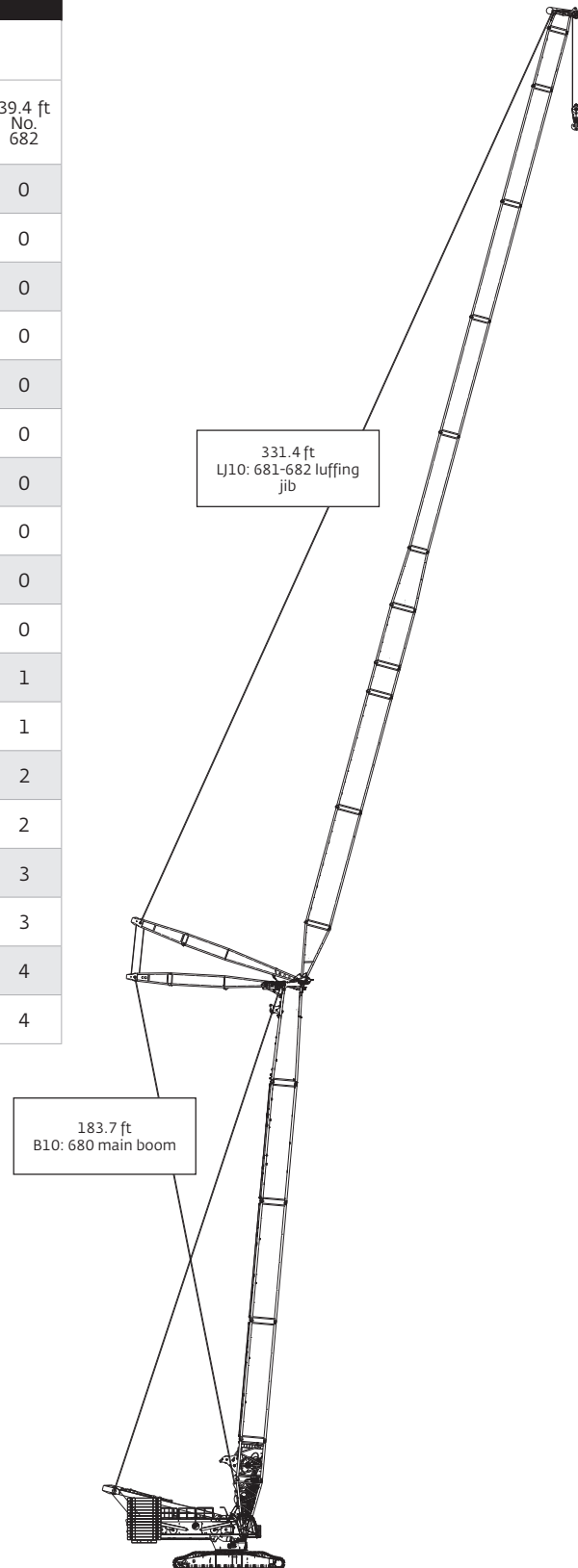

*THIS CHART IS ONLY A GUIDE AND SHOULD NOT BE USED TO OPERATE THE CRANE.  
The individual crane's load chart, operating instructions and other instructional plates must be read and understood prior to operating the crane*

# Main boom range diagram

**B10: 680 boom**

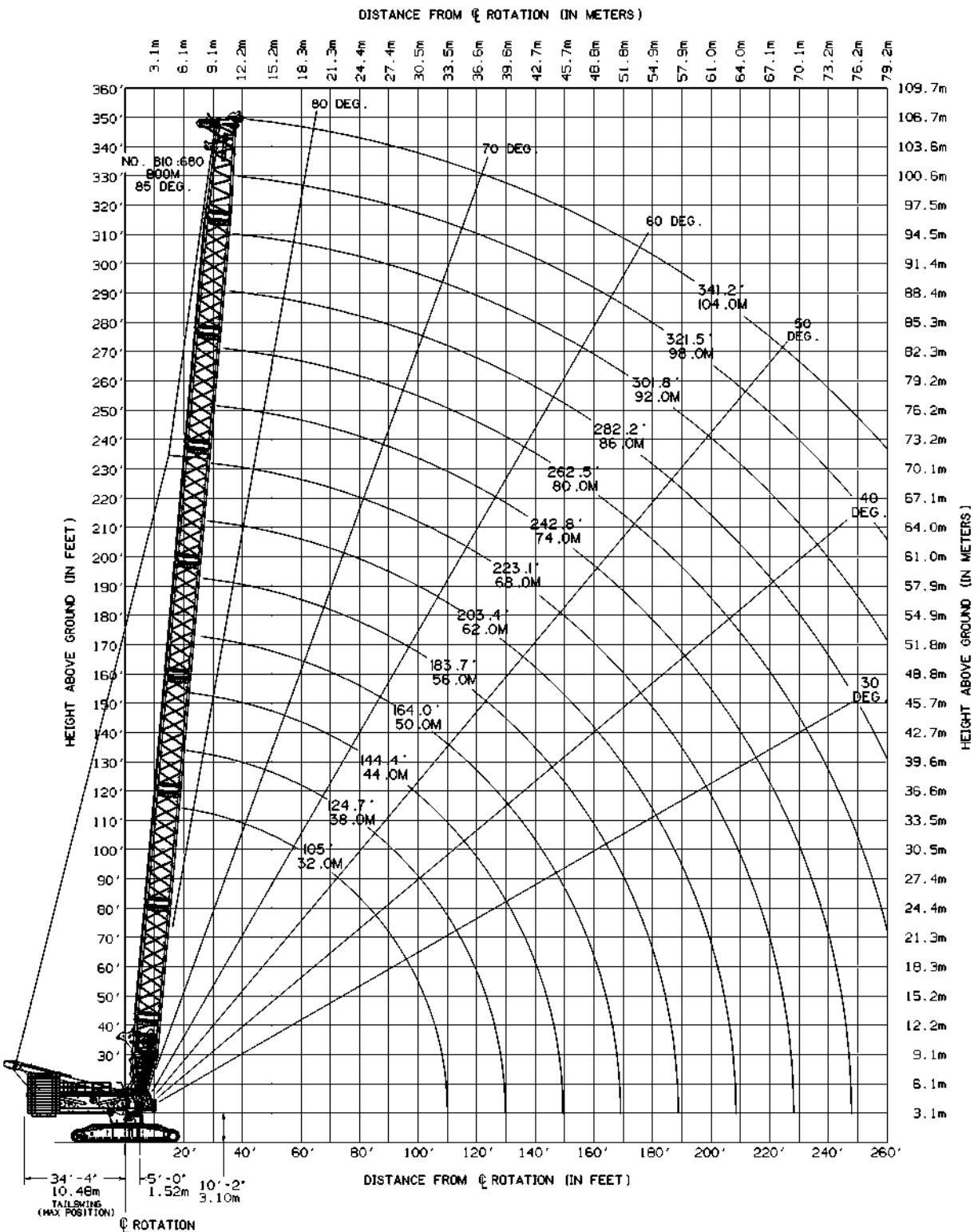

THIS CHART IS ONLY A GUIDE AND SHOULD NOT BE USED TO OPERATE THE CRANE.

The individual crane's load chart, operating instructions and other instructional plates must be read and understood prior to operating the crane

# Main boom load chart

B10: 680 boom with series 3													
881,800 lb counterweight													
360° Rating													
Radius (ft)	lb x 1000												
	Boom length (ft)												
	105	125	144	164	184	203	223	243	262	282	302	322	341
19	1433.0												
20	1300.8												
24	1123.2	1105.3	1083.9	1061.4									
28	987.5	974.5	958.5	942.0	925.5	905.5							
32	880.5	870.8	858.4	845.9	833.4	818.1	797.8	778.8					
36	794.1	786.6	776.8	767.1	757.3	745.5	729.1	714.0	702.4	604.2	518.1		
40	722.7	716.9	708.9	701.3	693.5	684.1	670.7	658.6	649.1	600.5	514.7	443.1	384.5
45	649.4	645.1	638.7	632.9	627.0	619.8	609.0	599.7	592.2	582.6	510.5	439.5	381.2
50	589.3	586.0	580.8	576.3	571.7	566.1	557.2	549.8	543.9	536.2	506.5	435.8	378.0
60	496.6	494.6	490.9	488.1	485.1	481.6	475.2	470.4	466.4	461.3	455.7	428.9	371.9
70	409.2	413.6	416.1	419.9	420.6	418.3	413.3	410.1	407.3	403.8	399.8	397.6	365.7
80	345.3	349.2	351.3	354.6	358.0	361.2	361.5	362.8	360.8	358.2	355.4	354.3	350.7
90	298.1	301.7	303.4	306.3	309.3	312.1	312.2	314.8	316.8	319.3	319.3	308.3	303.7
100	261.8	265.1	266.6	269.2	271.9	274.4	274.3	276.7	278.4	280.6	278.2	265.9	261.9
110		236.1	237.4	239.8	242.2	244.5	244.3	246.4	248.0	245.1	241.3	231.2	227.5
120		212.5	213.7	215.9	218.1	220.2	219.9	221.8	220.3	214.4	210.7	202.2	198.7
130			194.1	196.1	198.1	200.1	199.7	197.3	194.2	188.4	184.8	177.1	174.2
140			175.8	179.4	181.3	180.6	180.3	174.7	171.8	166.2	162.7	155.2	152.4
150				160.0	161.7	160.0	160.2	154.9	152.3	146.8	143.5	136.3	133.5
160				137.1	142.2	141.7	142.5	137.5	135.1	129.9	126.7	119.7	116.9
170					123.9	125.0	126.6	121.9	119.9	114.8	111.8	105.0	102.3
180					105.5	109.5	112.1	107.9	106.2	101.4	98.5	92.0	89.3
190						94.6	98.7	95.1	93.8	89.2	86.6	80.2	77.6
200						79.5	86.0	83.3	82.4	78.1	75.7	69.6	67.0
210							73.8	72.2	71.9	68.0	65.8	59.9	57.4
220							61.0	61.6	62.1	58.6	56.6	51.0	48.6
230								51.2	52.8	49.8	48.1	42.7	40.5
240								40.1	43.8	41.5	40.2	35.1	33.0
250									34.8	33.5	32.7	28.0	26.0
260										25.8	25.6	21.2	19.5
270										18.0	18.7		

B10: 680 boom with series 2													
661,300 lb counterweight													
360° Rating													
Radius (ft)	lb x 1000												
	Boom length (ft)												
	105	125	144	164	184	203	223	243	262	282	302	322	341
19	1433.0												
20	1245.8												
24	1075.4	1058.6	1038.5	1017.4									
28	945.3	933.1	918.1	902.6	887.2	868.5							
32	842.8	833.6	822.0	810.4	798.7	784.4	765.3	747.6					
36	759.9	752.9	743.7	734.7	725.6	714.5	699.1	685.1	674.2	604.2	518.1		
40	691.5	686.1	678.6	671.5	664.3	655.5	642.9	631.7	622.8	600.5	514.7	443.1	384.5
45	621.3	617.2	611.3	605.9	600.4	593.7	583.5	574.9	567.9	559	510.5	439.5	381.2
50	538.0	544.4	548.4	551.6	547.3	542.1	533.7	526.9	521.3	514.2	506.5	435.8	378
60	418.9	424.2	427.2	431.8	436.6	441.1	441.9	446.2	446.8	442.1	436.9	428.9	371.9
70	342.0	346.5	348.9	352.8	356.7	360.5	361.0	364.5	367.2	370.6	373.1	378.7	365.7
80	288.3	292.2	294.2	297.5	300.9	304.1	304.4	307.4	309.7	312.5	314.7	319.7	321.6
90	248.5	252.1	253.8	256.7	259.7	262.5	262.6	265.2	267.2	269.7	271.5	271.2	269.3
100	218.0	221.2	222.7	225.3	228	230.5	230.5	232.8	234.6	234.1	232.4	229.2	227.2
110		196.8	198.1	200.5	202.9	205.2	205.0	205.9	204.3	201	199.2	195.9	193.9
120		176.9	178.1	180.3	182.5	182.3	182.1	179.0	177.5	174	172.2	168.8	166.8
130			161.5	163.5	162.8	160.1	159.9	156.8	155.2	151.7	149.8	146.4	144.3
140			147.4	146.3	144	141.3	141.1	138.0	136.4	132.8	131.0	127.4	125.4
150				130.1	127.9	125.3	125.1	121.9	120.3	116.8	114.9	111.3	109.2
160				115.8	113.8	111.3	111.2	108.0	106.4	102.8	100.9	97.3	95.2
170					101.5	99.1	99.0	95.9	94.2	90.7	88.8	85.1	83.0
180					90.4	88.3	88.3	85.1	83.5	80.0	78.0	74.4	72.2
190						78.6	78.7	75.6	74.0	70.4	68.5	64.8	62.7
200						69.7	70.1	67.0	65.5	61.9	60.0	56.3	54.2
210							62.2	59.3	57.8	54.2	52.3	48.6	46.5
220							54.9	52.2	50.8	47.3	45.4	41.7	39.6
230								45.7	44.4	40.9	39.0	35.4	33.2
240								39.7	38.5	35.1	33.3	29.6	27.5
250									33.1	29.7	27.9	24.3	22.2
260										24.8	23.0	19.4	17.3
270										18.0	18.4		

For complete chart, refer to [www.cranelibrary.com](http://www.cranelibrary.com).

**THIS CHART IS ONLY A GUIDE AND SHOULD NOT BE USED TO OPERATE THE CRANE.**

The individual crane's load chart, operating instructions and other instructional plates must be read and understood prior to operating the crane

# Extended upper boom point range diagram

**B40: 680-681-682 with 25 ft extended upper boom point**

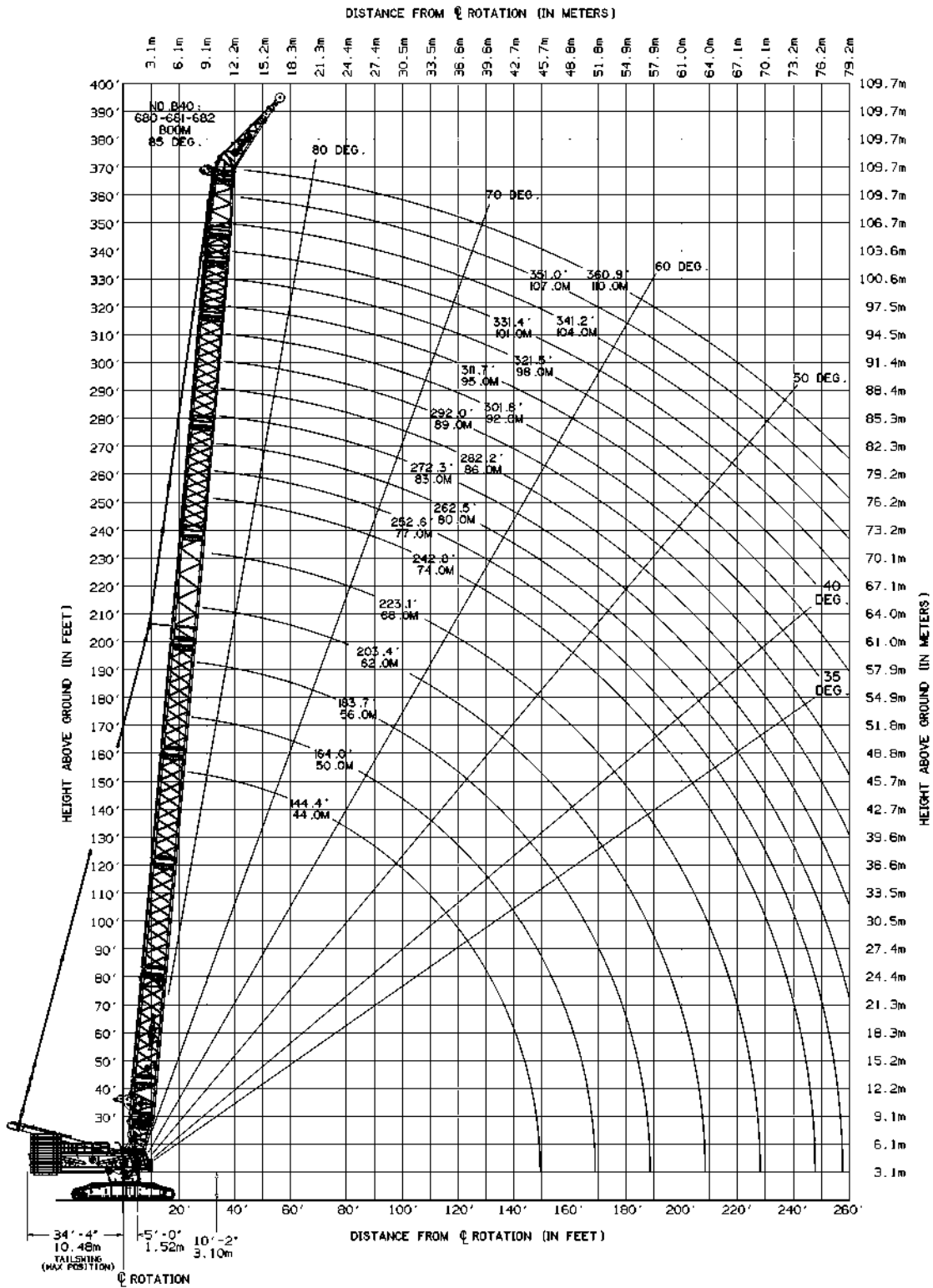

THIS CHART IS ONLY A GUIDE AND SHOULD NOT BE USED TO OPERATE THE CRANE.  
 The individual crane's load chart, operating instructions and other instructional plates must be read and understood prior to operating the crane

# Extended upper boom point load charts

B40: 680-681-682 boom with 23 ft extended upper boom point series 2												
661,300 lb counterweight												
360° Rating	lb x 1000 28° Offset											
	Boom length (ft)											
Radius (ft)	144	164	184	203	223	243	262	282	302	322	341	361
32	292.8											
34	292.8	292.8										
36	292.8	292.8	292.8									
38	292.8	292.8	292.8	292.8								
40	292.8	292.8	292.8	292.8	292.8	292.8						
45	292.8	292.8	292.8	292.8	292.8	292.8	292.8	292.8				
50	292.8	292.8	292.8	292.8	292.8	292.8	292.8	292.8	292.8	292.8	292.8	
60	292.8	292.8	292.8	292.8	292.8	292.8	292.8	292.8	292.8	292.8	276.8	250
70	292.8	292.8	292.8	292.8	292.8	292.8	292.8	292.8	292.8	292.8	262.5	236
80	292.8	292.8	292.8	292.8	292.8	292.8	292.8	292.8	292.8	280	249.7	223.5
90	257.8	259.8	262.3	264.2	267.7	269.5	270.8	273.9	272.2	268.4	238.2	212.2
100	227.1	229	231.1	232.8	235.9	237.5	238.5	241.4	244.3	245.8	227.7	202.1
110	202.8	204.5	206.4	208	210.7	212.2	213	215.6	218.3	218.5	218	193
120	183.1	184.6	186.3	187.7	190.2	191.5	192.2	194.7	192.7	190.9	190.5	184.6
130	166.7	168.1	169.7	171	173.2	174.5	174.6	173.2	169.9	168.1	167.6	165.7
140	152.9	154.3	155.6	156.9	158.9	158	155.5	154.1	150.7	148.9	148.4	146.4
150	141.1	142.4	143.7	144.9	143.2	141.8	139.2	137.7	134.3	132.5	131.9	129.9
160		132.2	133.4	133.3	129.1	127.7	125.1	123.6	120.1	118.3	117.7	115.7
170		123.3	122.1	121	116.8	115.4	112.7	111.2	107.7	105.9	105.3	103.2
180			111.2	110.1	105.9	104.5	101.8	100.3	96.8	94.9	94.4	92.3
190			101.3	100.4	96.3	94.8	92.2	90.6	87.1	85.2	84.7	82.6
200				91.7	87.6	86.2	83.5	82	78.4	76.5	76	73.9
220					72.5	71.2	68.6	67.1	63.5	61.7	61.1	59
240						58.7	56.2	54.8	51.2	49.4	48.8	46.7
260							45.7	44.3	40.8	39	38.5	36.4
280								35.3	31.8	30.1	29.6	27.5
300										22.3	21.9	19.9
320											15.2	

B40: 680-681-682 boom with 23 ft extended upper boom point series 2												
661,300 lb counterweight												
360° Rating	lb x 1000 35° Offset											
	Boom length (ft)											
Radius (ft)	144	164	184	203	223	243	262	282	302	322	341	361
34	292.8											
36	292.8	292.8										
38	292.8	292.8	292.8									
40	292.8	292.8	292.8	292.8								
45	292.8	292.8	292.8	292.8	292.8	292.8	292.8					
50	292.8	292.8	292.8	292.8	292.8	292.8	292.8	292.8	292.8	292.8		
60	292.8	292.8	292.8	292.8	292.8	292.8	292.8	292.8	292.8	289.9	263.4	239.5
70	292.8	292.8	292.8	292.8	292.8	292.8	292.8	292.8	292.8	277.5	250.5	226.6
80	292.8	292.8	292.8	292.8	292.8	292.8	292.8	292.8	292.8	266.2	239	215.1
90	258	260	262.5	264.4	267.9	269.7	271	274.1	277.4	255.9	228.5	204.7
100	227.3	229.1	231.3	233	236.1	237.7	238.7	241.5	244.5	246	219.1	195.3
110	202.9	204.6	206.5	208.1	210.8	212.3	213.1	215.8	218.5	219.8	210.4	186.8
120	183.2	184.7	186.4	187.9	190.3	191.7	192.3	194.8	194.1	192.4	192	179.1
130	166.8	168.2	169.8	171.1	173.3	174.6	175.1	174.3	171.2	169.4	169	167.1
140	153	154.3	155.7	157	159	158.9	156.5	155.1	151.8	150.1	149.6	147.6
150		142.5	143.8	144.9	143.9	142.5	140	138.6	135.3	133.5	133	131.1
160		132.3	133.4	133.8	129.8	128.3	125.8	124.4	121	119.2	118.7	116.7
170			122.4	121.4	117.4	115.9	113.4	111.9	108.5	106.7	106.2	104.2
180			111.4	110.5	106.4	105	102.4	101	97.5	95.7	95.2	93.2
190				100.7	96.6	95.3	92.7	91.2	87.8	85.9	85.4	83.4
200					87.9	86.5	84	82.5	79	77.2	76.7	74.6
220						71.5	69	67.5	64	62.2	61.7	59.6
240							56.4	55.1	51.6	49.8	49.3	47.2
260								44.5	41.1	39.3	38.8	36.8
280										30.3	29.9	27.9
300											22.1	20.1
315											16.5	15

For complete chart, refer to [www.cranelibrary.com](http://www.cranelibrary.com).

THIS CHART IS ONLY A GUIDE AND SHOULD NOT BE USED TO OPERATE THE CRANE.  
The individual crane's load chart, operating instructions and other instructional plates must be read and understood prior to operating the crane

# Luffing jib range diagram

LJ10: 681-682 luffing jib on B10:680 boom

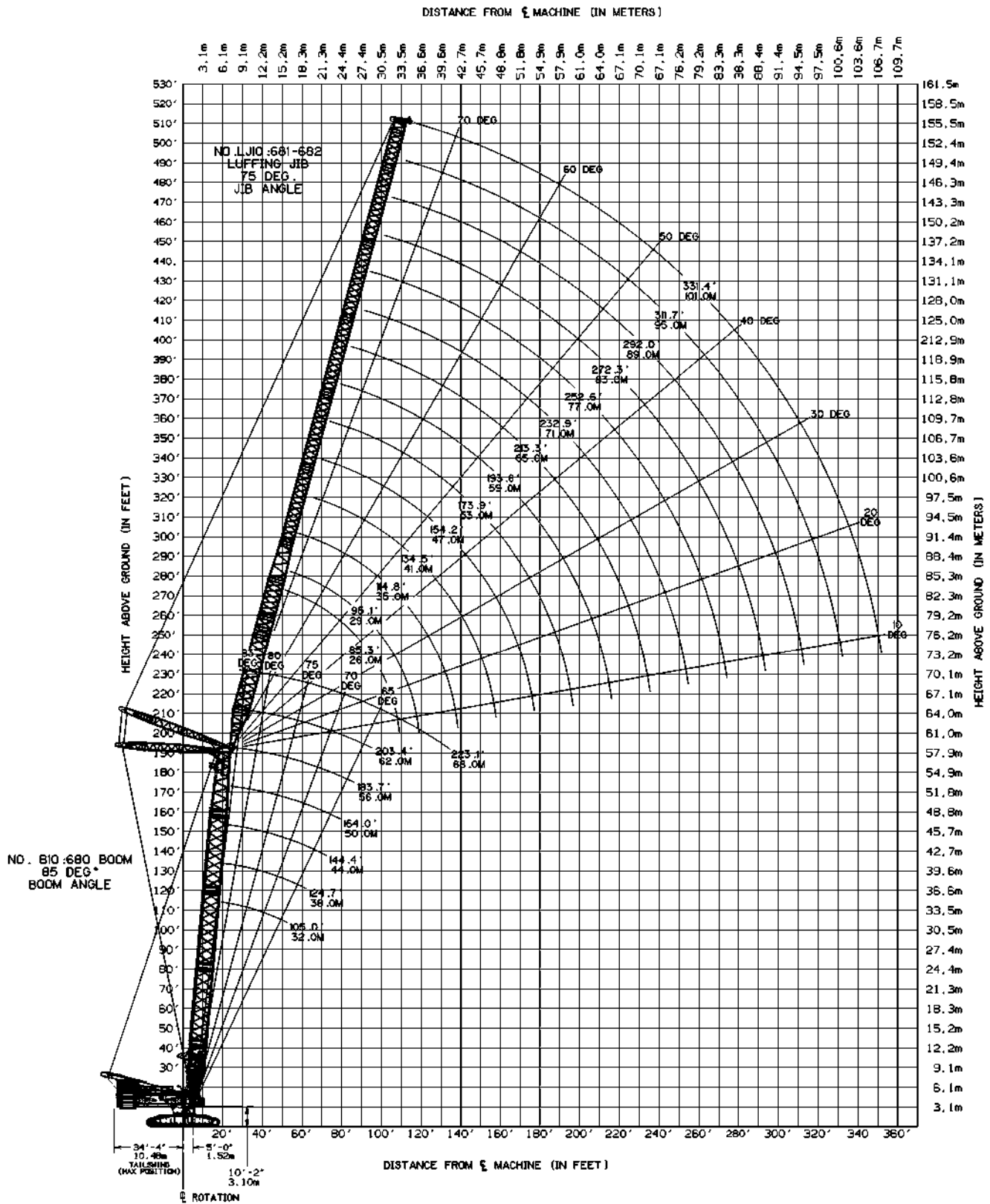

THIS CHART IS ONLY A GUIDE AND SHOULD NOT BE USED TO OPERATE THE CRANE.

The individual crane's load chart, operating instructions and other instructional plates must be read and understood prior to operating the crane



# Luffing jib load charts

## LJ10: 681-682 luffing jib on B10:680 boom series 3

881,800 lb counterweight

360° Rating

kg x 1000 85° boom angle

125 ft boom length					
Radius (ft)	luffing jib length (ft)				
	85	135	194	272	331
50	549.4				
60	471.1	455.2			
70	412.1	400.5			
80	366.2	357.3	342.1		
90	320.8	322.3	310.2		
100	283.4	286.4	283.6	201.4	
110		256.4	258.4	199.3	122.9
120		232.1	233.7	197	121.2
130		211.9	213.3	194.5	119
140		194.9	196.1	188.9	117.1
150		180.3	181.4	171.9	115.2
160			166.5	156.9	113.3
170			153	143.7	111.4
180			141	131.9	109.5
190			130.3	121.3	107.7
200			120.5	111.9	103.2
220				95.5	87.1
240				81.9	73.7
260				70.3	62.3
280				60.1	52.5
300					43.9
320					36.3
340					29.1

164 ft boom length					
Radius (ft)	luffing jib length (ft)				
	85	135	194	272	331
50	534.2				
60	460.9				
70	404.9	390.6			
80	360.8	350	330.9		
90	325.4	316.7	303.9		
100	287.5	289.1	278.6	177	
110		260.1	257	175.6	
120		235.4	235.5	174	110.4
130		214.9	212.7	172.1	109
140		197.7	193.2	170.2	107.6
150		182.9	176.3	165.3	106.1
160			161.5	150.9	104.5
170			148.4	138.3	103
180			136.8	126.9	101.4
190			126.3	116.7	99.9
200			116.8	107.6	98.3
220				91.8	82.9
240				78.5	69.9
260				67.2	58.9
280				57.4	49.3
300					41
320					33.7
340					26.8

203 ft boom length				
Radius (ft)	luffing jib length (ft)			
	85	135	194	272
55	480.5			
60	448.9			
70	396.4	380.7		
80	354.6	342.6		
90	320.6	311.1	279.9	
100	292	284.7	273.6	
110	261.4	262.4	252.5	157.5
120		237.6	226.7	156.1
130		215.1	204.9	154.4
140		195.7	186.1	152.6
150		178.9	169.8	150.7
160		163.8	155.5	144.1
170			142.9	131.9
180			131.6	121
190			121.5	111.3
200			112.4	102.5
220				87.2
240				74.4
260				63.5
280				54

223 ft boom length			
Radius(ft)	luffing jib length (ft)		
	85	135	194
55	471.3		
60	441.2		
70	390.7	356.8	
80	350.3	337.8	
90	317.3	307.4	238.3
100	289.9	281.7	234.9
110	262.4	258.8	230.2
120		232.9	220.9
130		210.9	199.9
140		192.1	181.7
150		175.7	165.8
160		161	151.9
170			139.6
180			128.7
190			118.8
200			109.9
220			94

For complete chart, refer to [www.cranelibrary.com](http://www.cranelibrary.com).

THIS CHART IS ONLY A GUIDE AND SHOULD NOT BE USED TO OPERATE THE CRANE.  
The individual crane's load chart, operating instructions and other instructional plates must be read and understood prior to operating the crane

# Luffing jib load charts

## LJ10: 681-682 luffing jib on B10: 680 boom series 2

661,300 lb counterweight    360° Rating    kg x 1000 85° boom angle

125 ft boom length					
Radius (ft)	luffing jib length (ft)				
	85	135	194	272	331
50	527				
60	451.8	437			
70	371.6	376.3			
80	315.3	319.2	322.7		
90	273.7	277.1	279.9		
100	241.7	244.7	247.1	201.4	
110		219.1	221	199.3	122.9
120		198.2	199.9	197	121.2
130		180.9	182.3	179.1	119
140		166.4	167.1	161.1	117.1
150		153.9	151.7	145.6	115.2
160			138.3	132.3	113.3
170			126.5	120.7	111.4
180			116.1	110.4	104.6
190			106.8	101.3	95.5
200			98.4	93.1	87.3
220				79.2	73.4
240				67.6	61.9
260				57.7	52.2
280				49.1	44
300					36.8
320					30.4
340					24.7

164 ft boom length					
Radius (ft)	luffing jib length (ft)				
	85	135	194	272	331
50	512.9				
60	442.3				
70	377.8	375.1			
80	320.6	324.5	320.8		
90	278.3	281.7	284.5		
100	245.8	248.8	251.1	177	
110		222.7	224.7	175.6	
120		201.5	203.2	174	110.4
130		184	183.2	172.1	109
140		169.2	165.3	158.9	107.6
150		154.5	150	143.6	106.1
160			136.7	130.4	104.5
170			125.1	118.9	103
180			114.8	108.8	101.4
190			105.6	99.8	93.8
200			97.3	91.7	85.7
220				77.9	72
240				66.4	60.6
260				56.7	51
280				48.2	42.9
300					35.8
320					29.5
340					23.9

203 ft boom length				
Radius (ft)	luffing jib length (ft)			
	85	135	194	272
55	461.6			
60	431.1			
70	380.5	365.8		
80	326.5	329		
90	283.4	286.8	279.9	
100	250.3	253.3	255.6	
110	224	226.7	227	157.5
120		205.2	201.7	156.1
130		186.4	180.7	154.4
140		168.4	163	152.6
150		152.8	147.8	141.2
160		138.6	134.7	128.2
170			123.2	116.8
180			113.1	106.8
190			104	97.9
200			95.8	89.9
220				76.3
240				65
260				55.4
280				47.1

223 ft boom length			
Radius (ft)	luffing jib length (ft)		
	85	135	194
55	452.9		
60	423.8		
70	375.2	356.8	
80	327.8	324.6	
90	284.6	288	238.3
100	251.4	254.3	234.9
110	225	227.7	225.4
120		206	200.3
130		185.3	179.4
140		167.4	161.8
150		151.9	146.7
160		138.1	133.7
170			122.3
180			112.2
190			103.2
200			95
220			80.5

THIS CHART IS ONLY A GUIDE AND SHOULD NOT BE USED TO OPERATE THE CRANE.  
The individual crane's load chart, operating instructions and other instructional plates must be read and understood prior to operating the crane

# Outline dimensions

VPC-MAX®

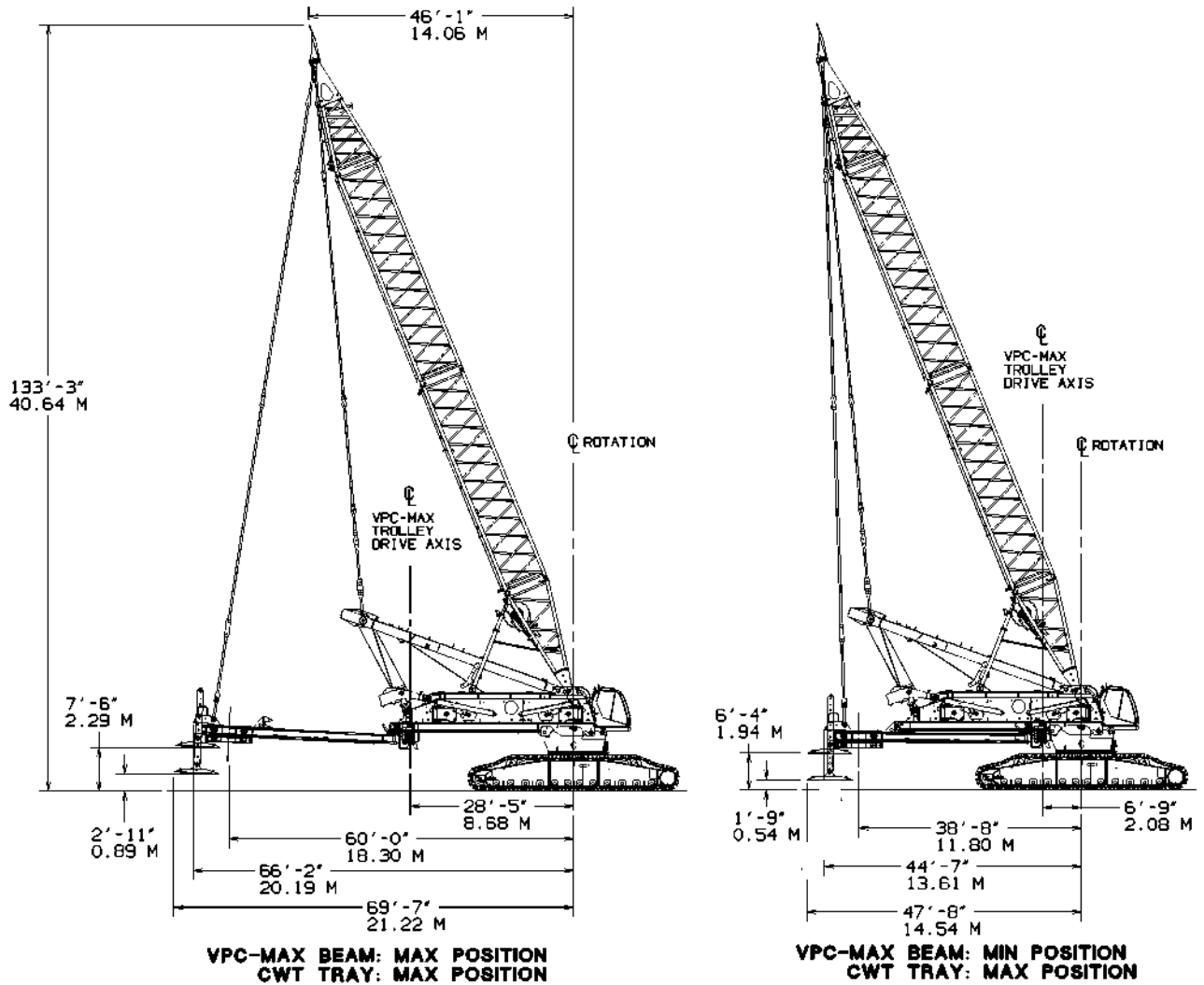

THIS CHART IS ONLY A GUIDE AND SHOULD NOT BE USED TO OPERATE THE CRANE.  
The individual crane's load chart, operating instructions and other instructional plates must be read and understood prior to operating the crane

# Transport data

VPC-MAX®

Load summary																																										
Item	282 ft boom																																									
	Quantity on trailer load #																																									
	(Does not include blocking, strapping, etc.)																																									
	Qty	Weight lb	1	2	3	4	5	6	7	8	9	10	11	12	13	14	15	16	17	18	19	20	21	22	23	24	25	26	27	28	29	30	31	32	33	34	35	36	37			
Upperworks module (with jacks)	1	85,800	1																																							
Whip hoist	1	12,800								1																																
Live mast package	1	59,300	1																																							
Carbody + adapter	1	91,500		1																																						
Crawler assembly (1,5 m pads)	2	85,800			1	1																																				
Counterweight tray	1	44,100					1																																			
Counterweight box	38	22,000															2	2	2	2	2	2	2	2	2	2	2	2	2	2	2	2	2	2	2	2	2	2	2	2	2	
Boom butt with drum 1	1	42,300						1																																		
13.1 ft No. 680 boom insert with drum 2	1	39,000							1																																	
39.4 ft No. 680 extra heavy boom insert with sheaves	1	27,800								1																																
39.4 ft No. 680 extra heavy boom insert	1	25,600									1																															
39.4 ft No. 680 heavy boom insert	1	21,400										1																														
39.4 ft No. 680 heavy boom insert with equalizer rails	1	23,400											1																													
19.7 ft No. 680 heavy boom insert	1	12,600												1																												
39.4 ft No. 680 medium insert with suspension	1	19,600													1																											
32.8 ft No. 680 boom top	1	41,400														1																										
350 USt block	1	17,400												1																												
24.5 USt weight ball	1	2,900										1																														
VPC-MAX beam	1	47,000																																							1	
VPC-MAX aux member	1	9,500																																							1	
VPC-MAX actuator	1	13,900													1																											
Fixed mast 6 m butt + 19.7 ft top	1	54,900																																						1		
39.4 ft lower mast insert	1	13,000																																						1		
39.4 ft upper mast insert	1	13,700																																							1	
Approximate total shipping weight lb			85,800	59,300	91,500	85,800	85,800	44,100	42,300	39,000	40,600	25,600	24,300	23,400	43,900	19,600	41,400	44,000	44,000	44,000	44,000	44,000	44,000	44,000	44,000	44,000	44,000	44,000	44,000	44,000	44,000	44,000	44,000	44,000	44,000	44,000	44,000	44,000	44,000	44,000		

THIS CHART IS ONLY A GUIDE AND SHOULD NOT BE USED TO OPERATE THE CRANE.  
 The individual crane's load chart, operating instructions and other instructional plates must be read and understood prior to operating the crane

# Boom combinations

VPC-MAX®

## B60: 680 VPC-MAX main boom combinations

Boom length (ft)	Main boom inserts				
	13.1 ft XH No. 680	39.4 ft XH No. 680	19.7 ft H No. 680	39.4 ft H No. 680	39.4 ft M No. 680
144.4	1	1	0	1	0
164	1	1	1	1	0
183.7	1	2	0	1	0
203.4	1	2	1	1	0
223.1	1	2	0	1	1
242.8	1	2	1	1	1
262.5	1	2	0	2	1
282.2	1	2	1	2	1
301.8	1	2	0	3	1
321.5	1	2	1	3	1
341.2	1	2	0	4	1
360.9	1	2	1	4	1
380.6	1	2	0	4	2
400.3	1	2	1	4	2
419.9	1	2	0	4	3
439.6	1	2	1	4	3
459.3	1	2	0	4	4
479.0	1	2	1	4	4

*XH: Extra heavy insert*

*H: Heavy insert*

*M: Medium insert*

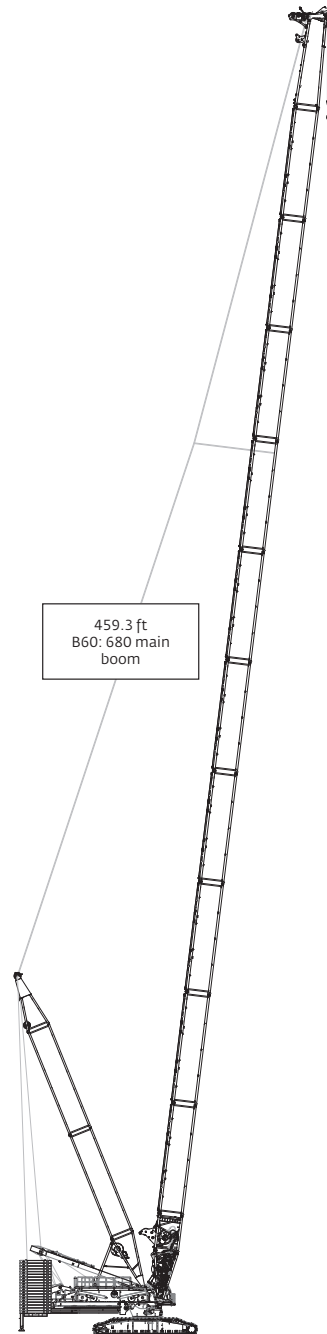

# Boom combinations

VPC-MAX®

## B80: 680-681-682 boom with 25 ft extended upper boom point

Boom length (ft)	Main boom inserts					
	13.1 ft XH No. 680	39.4 ft XH No. 680	39.4 ft H No. 680	19.7 ft H No. 680	39.4 ft M No. 680	
301.8	1	2	1	0	1	
321.5	1	2	1	0	1	
341.2	1	2	1	0	1	
360.9	1	2	2	1	1	
370.7	1	2	2	1	1	
380.6	1	2	2	1	1	
390.4	1	2	2	1	1	
400.3	1	2	2	1	1	
410.1	1	2	2	1	1	
419.9	1	2	3	1	1	
429.8	1	2	3	1	1	
439.6	1	2	3	1	1	
449.5	1	2	3	1	1	
459.3	1	2	3	1	1	
469.2	1	2	3	1	1	
479.0	1	2	3	1	1	
488.8	1	2	3	1	1	
498.7	1	2	3	1	1	
Boom length (ft)	Lifting jib inserts					
	19.7 ft No. 680-681	9.8 ft No. 681	19.7 ft No. 681	39.7 ft No. 681	39.7 ft No. 681-682	39.7 ft No. 682
301.8	1	1	0	0	1	0
321.5	1	1	1	0	1	0
341.2	1	1	0	1	1	0
360.9	1	1	0	0	1	0
370.7	1	0	1	0	1	0
380.6	1	1	1	0	1	0
390.4	1	0	0	1	1	0
400.3	1	1	0	1	1	0
410.1	1	0	1	1	1	0
419.9	1	1	1	0	1	0
429.8	1	0	0	1	1	0
439.6	1	1	0	1	1	0
449.5	1	0	1	1	1	0
459.3	1	1	1	1	1	0
469.2	1	0	0	1	1	1
479.0	1	1	0	1	1	1
488.8	1	0	1	1	1	1
498.7	1	1	1	1	1	1

XH: Extra heavy insert

H: Heavy insert

M: Medium insert

For complete chart, refer to [www.cranelibrary.com](http://www.cranelibrary.com).

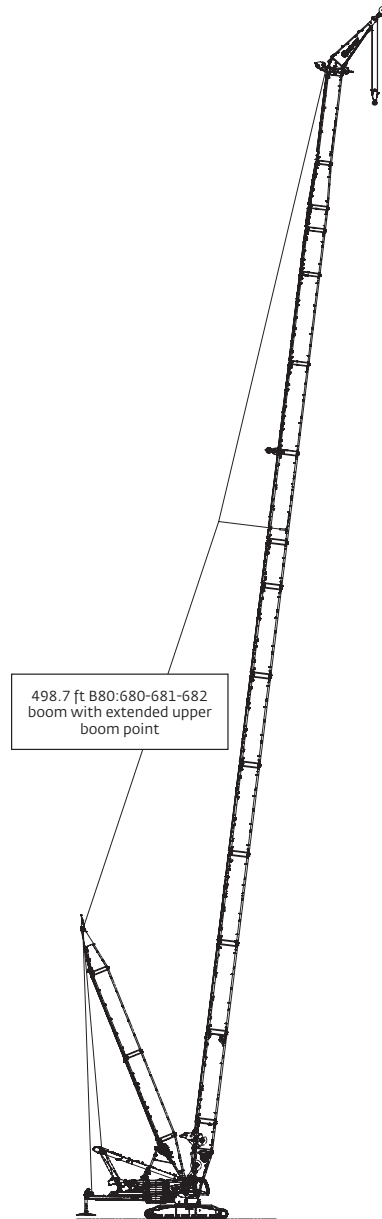

THIS CHART IS ONLY A GUIDE AND SHOULD NOT BE USED TO OPERATE THE CRANE.

The individual crane's load chart, operating instructions and other instructional plates must be read and understood prior to operating the crane

# Boom combinations

VPC-MAX®

LJ10: 681-682 VPC-MAX luffing jib combinations							
Luffing jib length (ft)	Luffing jib inserts						
	39.4 ft No. 680-681	9.8 ft No. 681	19.7 ft No. 681	39.4 ft No. 681	19.7 ft No. 681-682	19.7 ft No. 682	39.4 ft No. 682
85.3	1	0	0	0	1	0	0
95.1	1	1	0	0	1	0	0
105.0	1	0	1	0	1	0	0
114.8	1	1	1	0	1	0	0
124.7	1	0	0	1	1	0	0
134.5	1	1	0	1	1	0	0
144.4	1	0	1	1	1	0	0
154.2	1	1	1	1	1	0	0
164.0	1	0	1	1	1	1	0
173.9	1	1	1	1	1	1	0
193.6	1	1	1	1	1	0	1
213.3	1	1	1	1	1	1	1
232.9	1	1	1	1	1	0	2
252.6	1	1	1	1	1	1	2
272.3	1	1	1	1	1	0	3
292.0	1	1	1	1	1	1	3
311.7	1	1	1	1	1	0	4
331.4	1	1	1	1	1	1	4

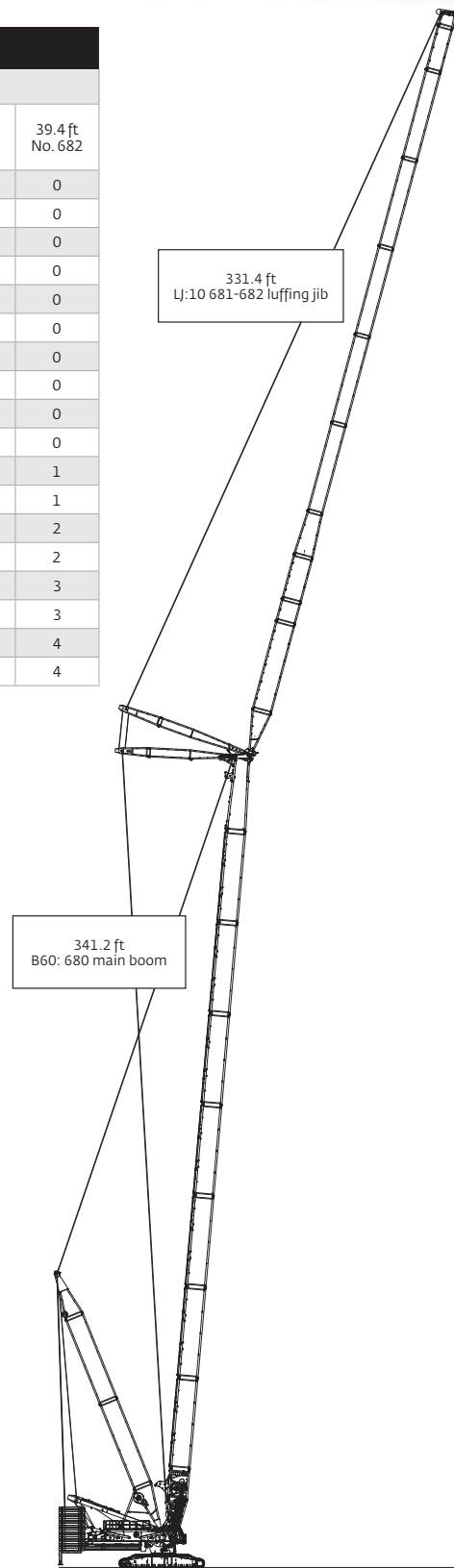

*THIS CHART IS ONLY A GUIDE AND SHOULD NOT BE USED TO OPERATE THE CRANE.  
The individual crane's load chart, operating instructions and other instructional plates must be read and understood prior to operating the crane*

# Main boom range diagram

VPC-MAX®

B60:680 boom with VPC-MAX

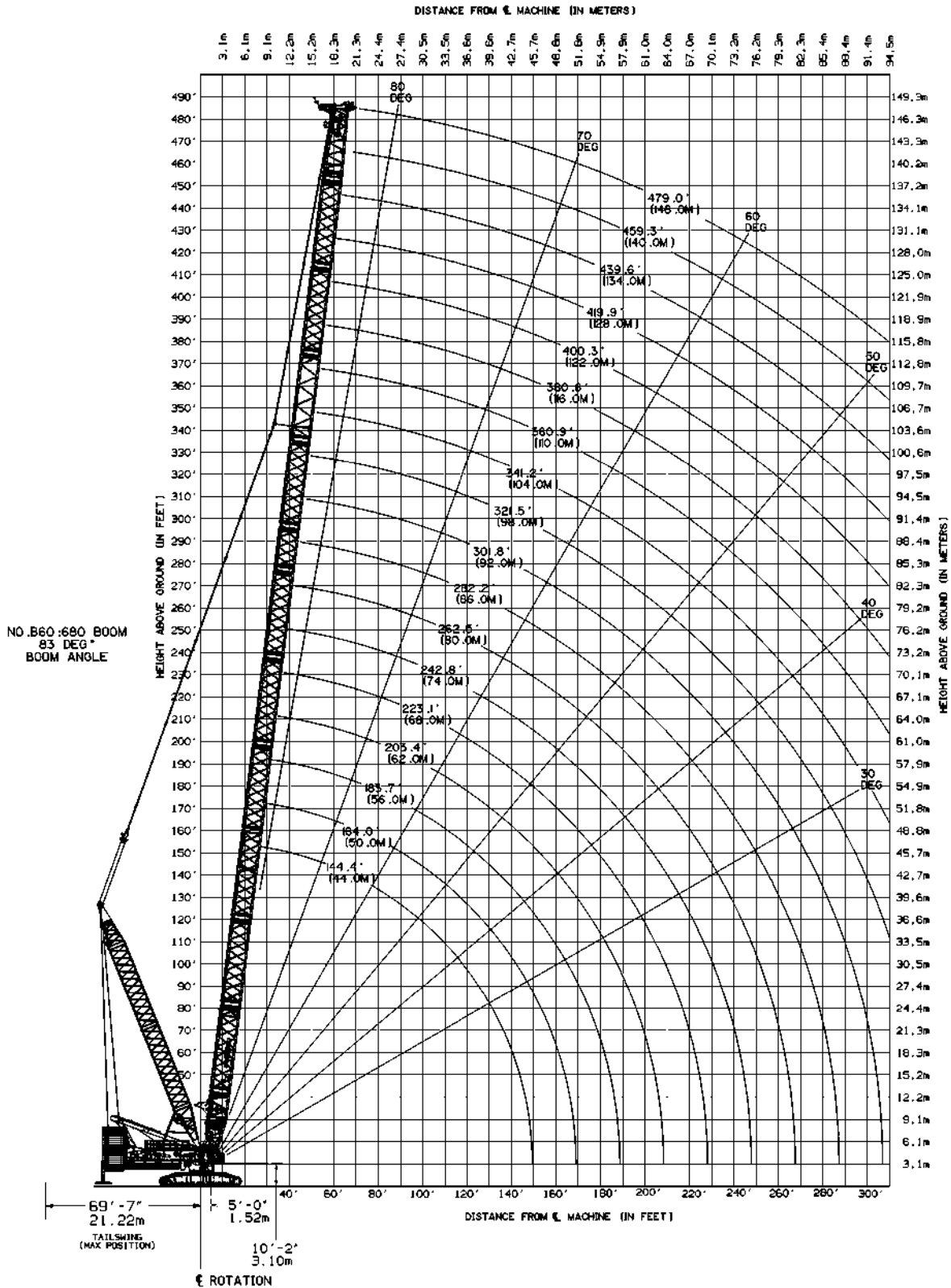

THIS CHART IS ONLY A GUIDE AND SHOULD NOT BE USED TO OPERATE THE CRANE.

The individual crane's load chart, operating instructions and other instructional plates must be read and understood prior to operating the crane



# Main boom load charts

VPC-MAX®

B60:680 boom with VPC-MAX										
881,800 lb Counterweight										
360° Rating	lb x 1000									
Radius (ft)	Boom Length (ft)									
	144	184	223	262	302	341	381	420	459	479
28	1349.5									
30	1312.3									
32	1277	1155.3								
34	1243.5	1127.2								
36	1211.6	1100.3								
38	1181.2	1074.5	973.3							
40	1152.2	1049.9	953							
45	1085.3	992.5	905.2	809.3						
50	1085.3	940.6	861.5	786.5	589.7					
60	1085.3	940.6	813.5	720.9	589.7	461.3	348.1			
70	932.3	923.6	813.5	691.5	589.7	461.3	348.1	264.2	215.1	188.5
80	810.1	801.6	797.8	691.5	589.7	461.3	348.1	264.2	215	188.1
90	714.4	706.1	702.3	691.5	589.7	461.3	348.1	264.2	214.7	187.9
100	634.8	629	625.4	619.7	589.7	461.3	348.1	264.1	214.3	187.5
110	561.9	556.1	554.3	550.5	546	461.3	348.1	263.8	213.9	187.1
120	502.7	496.9	494.9	491	486.4	461.3	348.1	263.3	213.5	186.7
130	453.4	447.8	445.7	441.7	437	431.8	348.1	262.9	213	186.2
140	411.8	406.4	404.2	400.1	395.4	390.1	347.8	262.4	212.5	185.7
150		371	368.8	364.7	359.8	354.5	347.2	261.8	211.7	185.1
160		340.3	338.2	334	329.1	323.7	320.3	261.2	211.1	184.5
170		313.5	311.4	307.2	302.3	296.9	293.4	260.5	210.6	184
180		289.8	287.8	283.6	278.7	273.3	269.8	259.8	209.9	182.5
190			266.8	262.7	257.7	252.3	248.8	244.7	208.4	180.7
200			248.1	244	239	233.5	230	226	206.4	179
210			231.1	227.1	222.2	216.7	213.2	209.1	204.3	177.3
220			215.7	211.8	206.9	201.4	197.9	193.9	189.6	175.6
230				197.9	193.1	187.6	184.1	180	175.7	171.9
240				185.2	180.4	174.9	171.5	167.4	163.1	159.2
250				173.5	168.8	163.3	159.9	155.8	151.5	147.6
260					158.1	152.7	149.2	145.1	140.9	137
270					148.2	142.8	139.4	135.3	131	127.1
280					139	133.7	130.3	126.2	121.9	118
290					130.4	125.2	121.8	117.8	113.5	109.6
300						117.2	114	109.9	105.6	101.7
320						102.8	99.7	95.6	91.4	87.5
340							87.1	83.1	78.9	75
360							75.8	72	67.8	63.9
380								62	57.8	54
400								52.9	48.9	45
420									40.8	36.7
440									33.3	28
460										19.8

THIS CHART IS ONLY A GUIDE AND SHOULD NOT BE USED TO OPERATE THE CRANE.  
 The individual crane's load chart, operating instructions and other instructional plates must be read and understood prior to operating the crane

# Main boom extended boom point range diagram

VPC-MAX®

**B80: 680-681-682 boom with 25 ft extended upper boom point**

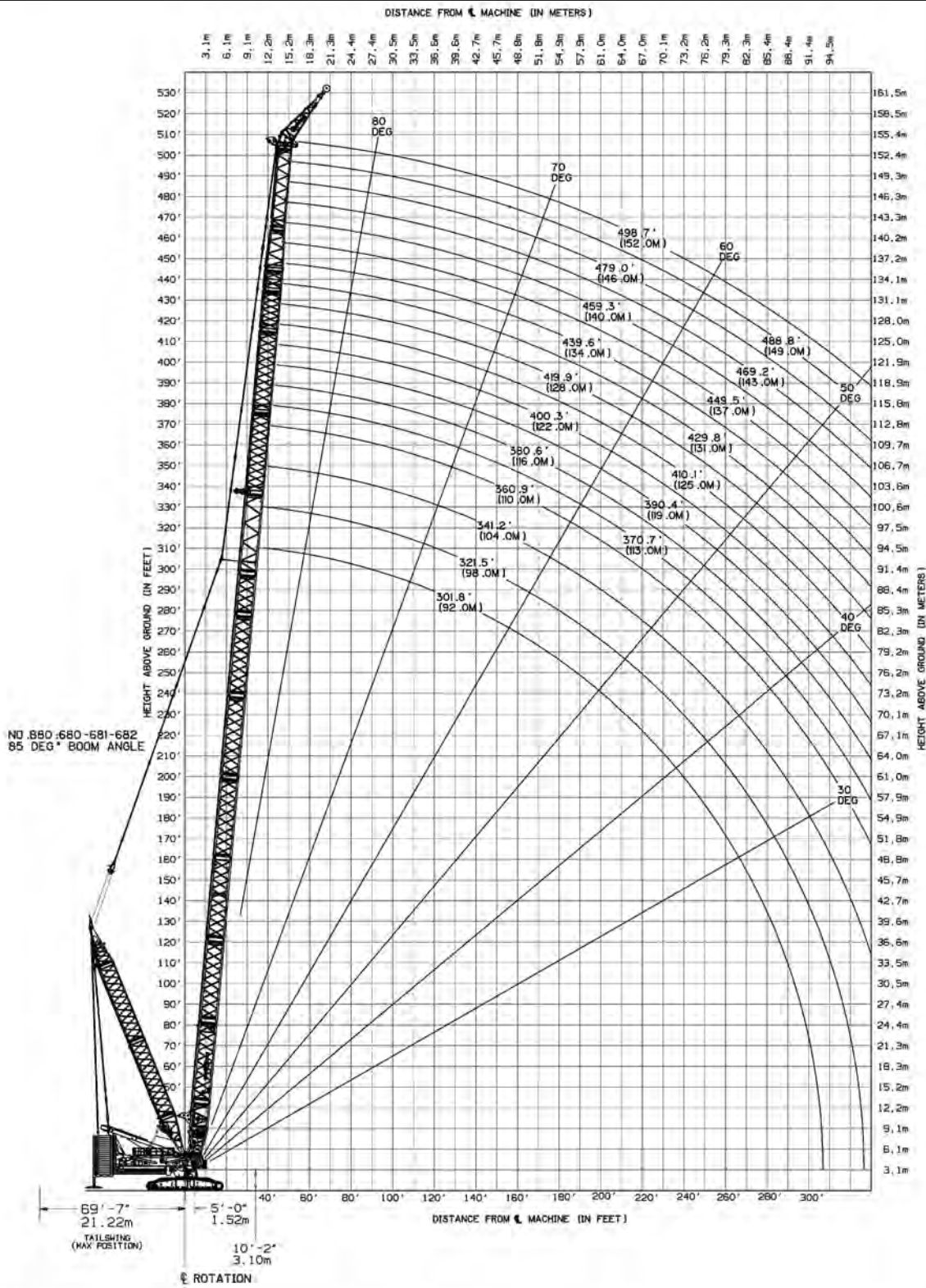

THIS CHART IS ONLY A GUIDE AND SHOULD NOT BE USED TO OPERATE THE CRANE.  
The individual crane's load chart, operating instructions and other instructional plates must be read and understood prior to operating the crane

# Main boom extended boom point load charts

VPC-MAX®

<b>B80: 680-681-682 Boom with extended upper boom point</b>											
<b>881,800 lb Counterweight</b>											
<b>360° Rating</b>	<b>lb x 1000 28° Offset</b>										
<b>Radius (ft)</b>	<b>Boom Length (ft)</b>										
	<b>302</b>	<b>322</b>	<b>341</b>	<b>361</b>	<b>381</b>	<b>400</b>	<b>420</b>	<b>440</b>	<b>459</b>	<b>479</b>	<b>499</b>
50	328.6	334	336								
60	327.8	334	336	341.6	310.5	274.5	250.9	223	197.5		
70	325.7	334	336	341.6	310.5	274.4	250.7	222.8	197.2	173.7	153.9
80	322.7	334	336	341.6	310.5	274.3	250.5	222.6	196.9	173.3	153.4
90	319.2	334	335.8	341.6	310.5	274.1	250.3	222.2	196.6	172.8	152.9
100	315.5	332.4	333	341.6	310.5	273.9	250	221.9	196.1	172.3	152.4
110	311.6	330.2	330	338.8	310.5	273.7	249.7	221.6	195.7	171.8	151.9
120	307.7	327.7	326.3	335.3	305.4	270	249.3	221.1	195.3	171.3	151.3
130	304	325.3	322.7	330.5	294.6	259.8	248.9	220.7	194.8	170.8	150.9
140	300.6	315.3	319.4	321.8	284.3	249.8	248.5	220.3	194.4	170.3	150.3
150	295.2	303.8	312	313.4	274.4	240.4	248.1	219.9	193.9	169.9	149.7
160	284.8	293.3	301.4	305.5	265	231.5	247.7	217.2	190.7	169.1	148.2
170	275.2	283.6	291.6	297.1	256.2	223.1	241.1	210.2	184.1	163.4	145
180	266.5	274.6	281.5	274.4	248.1	215.3	234	203.6	177.9	157.6	139.6
190	258.4	261.8	261.4	254.3	240.4	208	227.3	197.2	171.9	152.1	134.6
200	245.4	243.9	243.5	236.3	233.4	201.2	221	191.2	166.3	146.9	129.7
220	214.7	213.1	212.8	205.5	203.8	189.1	198.1	180.2	155.9	137.3	120.7
240	189.3	187.8	187.4	180.1	178.4	177.9	172.7	170.4	146.7	128.7	112.6
260	168	166.5	166.1	158.8	157.1	156.6	151.3	150.8	138.6	121.1	105.5
280	149.7	148.3	148	140.6	138.9	138.5	133.1	132.6	130.6	114.4	99.1
300		132.5	132.3	124.9	123.2	122.8	117.4	117	115	108.6	93.4
320			118.5	111.1	109.5	109.1	103.7	103.3	101.3	100.8	88.5
340				99	97.4	97.1	91.7	91.3	89.3	88.8	84.2
360					86.6	86.3	81	80.6	78.6	78.1	76
380						76.7	71.3	71	69.1	68.6	66.5
400							62.7	62.4	60.5	60	57.9
420									52.6	52.2	50.2
440										45.1	43.1
460											36.6

*THIS CHART IS ONLY A GUIDE AND SHOULD NOT BE USED TO OPERATE THE CRANE.  
The individual crane's load chart, operating instructions and other instructional plates must be read and understood prior to operating the crane*

# Main boom extended boom point load charts

VPC-MAX®

<b>B80: 680-681-682 Boom with extended upper boom point</b>											
<b>881,800 lb Counterweight</b>											
<b>360° Rating</b>	<b>lb x 1000 35° Offset</b>										
<b>Radius (ft)</b>	<b>Boom Length (ft)</b>										
	<b>302</b>	<b>322</b>	<b>341</b>	<b>361</b>	<b>381</b>	<b>400</b>	<b>420</b>	<b>440</b>	<b>459</b>	<b>479</b>	<b>499</b>
50	264.0	268.9									
60	264.0	268.9	274.8	285.3	286.9	272.2	249.2	222.0			
70	264.0	268.9	274.8	285.3	286.9	272.1	249.2	221.8	196.5	172.8	153.4
80	264.0	268.9	274.8	285.3	286.9	272.1	249.1	221.6	196.2	172.4	152.9
90	264.0	268.9	274.8	285.3	286.9	272.0	248.8	221.3	195.9	172	152.4
100	264.0	268.9	274.8	285.3	286.9	271.9	248.6	221.0	195.5	171.5	151.9
110	263.1	268.9	274.8	285.3	286.9	270.2	248.4	220.7	195.1	171.1	151.4
120	261.9	268.9	274.8	285.3	286.9	260.4	248.1	220.4	194.7	170.7	150.9
130	260.8	268.9	274.8	281.4	282.9	250.9	247.8	220.1	194.3	170.1	150.4
140	256.6	262.4	267.9	273	273.5	241.7	247.6	219.7	193.9	169.7	149.9
150	248.9	254.7	260.1	265.3	264.4	232.9	247.2	217.8	192.4	169.3	149.4
160	241.8	247.5	253	258.1	255.9	224.6	240.2	211.0	185.9	165.6	147.7
170	235.2	240.9	246.3	251.4	247.9	216.8	233.4	204.4	179.7	159.9	142.3
180	229.2	234.8	240.1	245.2	240.4	209.5	226.9	198.2	173.8	154.4	137.1
190	223.7	229.1	234.4	239.4	233.4	202.7	220.7	192.2	168.2	149.2	132.2
200	218.6	223.9	229.1	234.0	227.0	196.4	214.9	186.5	162.7	144.1	127.5
220	209.6	213.6	213.3	206.1	204.5	185.1	198.9	176.2	152.9	134.9	118.8
240	189.7	188.2	187.9	180.6	178.9	175.6	173.3	167	144.1	126.7	111.0
260	168.2	166.8	166.5	159.2	157.5	157.1	151.9	151.4	136.4	119.4	104.1
280	149.9	148.5	148.2	140.9	139.3	138.9	133.6	133.1	129.6	112.9	97.9
300			132.4	125.1	123.5	123.1	117.8	117.4	115.4	107.3	92.4
320				111.3	109.7	109.4	104.1	103.6	101.7	101.2	87.7
340					97.6	97.3	91.9	91.5	89.6	89.1	83.5
360						86.5	81.2	80.8	78.9	78.4	76.3
380								71.2	69.3	68.8	66.8
400									60.6	60.2	58.1
420										52.4	50.3
440											43.2

*THIS CHART IS ONLY A GUIDE AND SHOULD NOT BE USED TO OPERATE THE CRANE.  
The individual crane's load chart, operating instructions and other instructional plates must be read and understood prior to operating the crane*

# Main boom extended boom point load charts

VPC-MAX®

<b>B80: 680-681-682 Boom with extended upper boom point</b>											
<b>881,800 lb Counterweight</b>											
<b>360° Rating</b>	<b>lb x 1000 41° Offset</b>										
<b>Radius (ft)</b>	<b>Boom Length (ft)</b>										
	<b>302</b>	<b>322</b>	<b>341</b>	<b>361</b>	<b>381</b>	<b>400</b>	<b>420</b>	<b>440</b>	<b>459</b>	<b>479</b>	<b>499</b>
50	228.4										
60	228.4	234.9	238.5	243.9	243.9	243.9					
70	228.4	234.9	238.5	243.9	243.9	243.9	243.9	221.4	196.3	172.4	153.2
80	228.4	234.9	238.5	243.9	243.9	243.9	243.9	221.2	196.1	172	152.7
90	228.4	234.9	238.5	243.9	243.9	243.9	243.9	221.1	195.8	171.6	152.3
100	228.4	234.9	238.5	243.9	243.9	243.9	243.9	220.8	195.4	171.3	151.8
110	228.4	234.9	238.5	243.9	243.9	243.9	243.9	220.6	195.1	170.9	151.3
120	228.4	234.9	238.5	243.9	243.9	243.9	243.9	220.4	194.8	170.5	150.9
130	228.4	234.9	238.5	243.9	243.9	243.8	243.9	220.1	194.5	170.1	150.4
140	228.4	234.9	238.5	243.9	243.9	235.2	243.9	218.5	194.1	169.7	150
150	227.2	231.4	235.4	239.1	242.7	227	240.1	211.9	187.8	168.1	149.5
160	222	226.2	230.1	233.9	237.4	219.2	233.6	205.5	181.7	162.4	145.1
170	217.2	221.3	225.2	229	232.5	211.9	227.3	199.4	175.8	156.8	139.9
180	212.8	216.8	220.7	224.4	227.9	205	221.2	193.5	170.2	151.6	134.9
190	208.7	212.7	216.5	220.2	223.7	198.6	215.5	187.9	164.8	146.5	130.2
200	205	208.9	212.6	216.2	219.7	192.6	210.1	182.6	159.6	141.7	125.6
220	198.7	202.2	205.7	206.7	205	182	199.6	172.8	150.3	132.9	117.2
240	189.9	188.5	188.2	181.1	179.4	173	173.9	164.1	141.9	125	109.6
260	168.4	167	166.8	159.6	157.9	157.5	152.3	151.9	134.6	117.9	102.9
280			148.4	141.2	139.6	139.2	134	133.6	128.1	111.7	96.9
300				125.3	123.7	123.4	118.1	117.7	115.8	106.2	91.6
320						109.6	104.3	103.9	102	101.5	86.9
340							92.1	91.8	89.9	89.4	82.8
360								81	79.1	78.6	76.6
380										69	67
400											58.3

*THIS CHART IS ONLY A GUIDE AND SHOULD NOT BE USED TO OPERATE THE CRANE.  
The individual crane's load chart, operating instructions and other instructional plates must be read and understood prior to operating the crane*

# Luffing jib range diagram

VPC-MAX®

LJ10: 681-682 luffing jib on B60: 680 boom with VPC-MAX

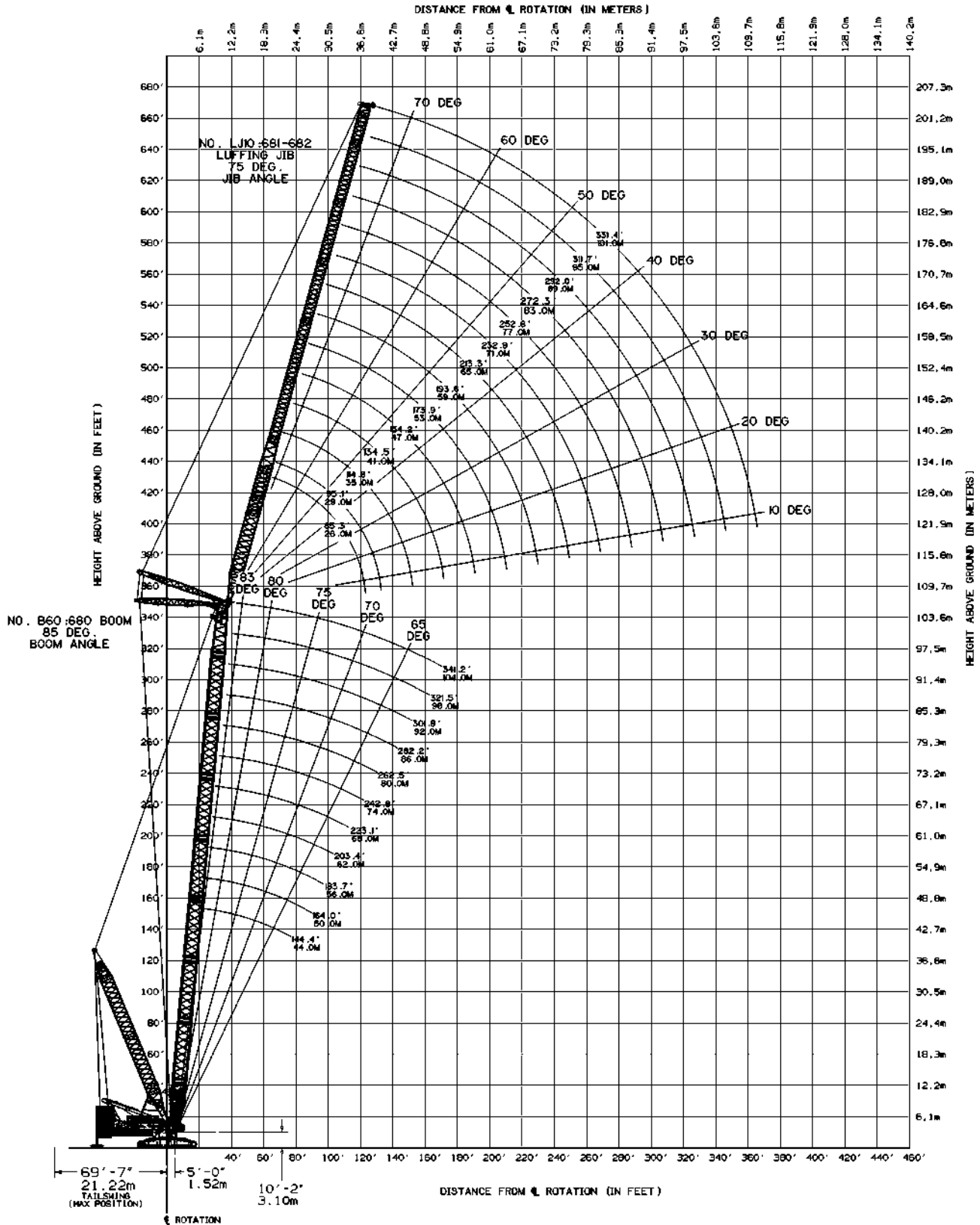

THIS CHART IS ONLY A GUIDE AND SHOULD NOT BE USED TO OPERATE THE CRANE.

The individual crane's load chart, operating instructions and other instructional plates must be read and understood prior to operating the crane

# Luffing jib load charts

VPC-MAX®

## LJ10: 681-682 luffing jib on B60: 680 boom VPC-MAX

881,800 lb counterweight    360° Rating    lb x 1000

85° boom angle

144 ft boom length					
Radius (ft)	Luffing jib length(ft)				
	85	135	194	272	331
50	733				
55	733				
60	733	592.5			
70	715	571.7			
80	649.5	550.2	379.4		
90	537.6	528.9	378.5		
100	380.4	490.1	370.4	195.3	
110		429.2	359.6	193.8	
120		380.4	338.1	192	118.8
130		338.9	311.8	190	117.3
140		295.7	285.9	187.9	115.6
150		228.4	261.4	185.7	113.9
160			238.8	183.4	112.1
170			218.7	177.9	110.4
180			201.2	168.5	108.6
190			186.6	159	106.9
200			168.2	149.7	105.3
220				132.2	102.1
240				116.8	97.4
260				104.2	88.6
280				84.4	80.2
300					72.8
320					60.9
340					45.4

203 ft boom length					
Radius (ft)	Luffing jib length (ft)				
	85	135	194	272	331
55	654.3				
60	631.7				
70	590.5	481.8			
80	562.8	476.6			
90	525.8	439.3	303.9		
100	459.6	399.8	301.9		
110	302.1	361.6	293.2	165.6	
120		326.6	274.7	164.7	106
130		296.4	255.4	163.5	104.9
140		271.9	236.3	162.1	103.8
150		255	217.9	160.4	102.5
160		189.1	200.8	157.3	101.3
170			185.3	149.6	99.9
180			171.7	141.7	98.5
190			160.2	133.9	97.1
200			151.2	126.2	95.8
220				111.7	90.5
240				99	82.2
260				88.7	74.3
280				81.5	67
300					60.5
320					55.4
340					50.7

For complete chart, refer to [www.cranelibrary.com](http://www.cranelibrary.com).

THIS CHART IS ONLY A GUIDE AND SHOULD NOT BE USED TO OPERATE THE CRANE.  
The individual crane's load chart, operating instructions and other instructional plates must be read and understood prior to operating the crane

# Luffing jib load charts

VPC-MAX®

## LJ10: 681-682 luffing jib on B60: 680 boom VPC-MAX

881,800 lb counterweight    360° Rating    lb x 1000

282 ft boom length					
Radius (ft)	Luffing jib length (ft)				
	85	135	194	272	331
60	389.8				
70	385.2				
80	374.2	280.2			
90	345	275.3	193.9		
100	314.4	268.1	192.8		
110	296.3	249.3	190.5	118.5	
120		230.5	186.2	117.9	
130		213.1	175.4	117	76.9
140		198.2	164.4	115.8	76.4
150		186.6	153.6	114.1	75.8
160		180.5	143.4	109	75
170			133.9	103.9	74.2
180			125.4	98.6	73.2
190			118	93.4	71.4
200			111.9	88.2	68.5
220			106.5	78.6	62.5
240				70.1	56.6
260				63.2	50.9
280				58.4	45.8
300				57.2	41.3
320					37.7
340					35.3

85° boom angle

341 ft boom length					
Radius (ft)	Luffing jib length (ft)				
	85	135	194	272	331
65	270.9				
70	266.8				
80	251.4	193			
90	245.2	190.5			
100	240.8	186.4	136.2		
110	233	181.7	134.5		
120	225.9	175.9	132.1	84.9	
130		165.4	129.1	84.3	58
140		155.2	124.7	83.3	57.6
150		146.8	117.5	82.2	57.2
160		141	110.6	80.6	56.5
170		139.7	104.1	77	55.5
180			98.1	73.3	53.4
190			92.8	69.6	51.2
200			88.3	66.1	48.9
220			83.1	59.2	44.3
240				53	39.8
260				47.9	35.6
280				44.3	31.7
300				43	28.3
320					25.7

For complete chart, refer to [www.cranelibrary.com](http://www.cranelibrary.com).

THIS CHART IS ONLY A GUIDE AND SHOULD NOT BE USED TO OPERATE THE CRANE.  
The individual crane's load chart, operating instructions and other instructional plates must be read and understood prior to operating the crane



# Specifications

## Upperworks

### Engine

Cummins Model QSX15 Tier 4 Final diesel, 600 HP at 1800 rpm or Cummins QSX15 Tier 3 diesel, rated 600 HP at 1800 rpm. Includes pump drive disconnect for easier starting, engine block heater (240V), high silencing muffler or emissions compliant Tier 4 Final aftertreatment, hydraulic oil cooler, radiator and variable speed hydraulic controlled fan. Variable speed fan provides increased fuel efficiency, decreased engine loading and reduced noise emission.

Multiple hydraulic pump drive transmission provides power for all machine functions. Two 12 volt, 1375 CCA at -18° C, 24 volt system and 110 amp alternator. 295 gal fuel tank, with level indicator in operator's cab.

**Optional:** Cold-weather package with heater for fluids.

### Crane Control System

The Crane Control System offers a user-friendly interface, two full graphic displays mounted horizontally for better visibility, a jog dial for easier data input and ergonomic joysticks.

### Hydraulic system

High-pressure piston pumps, driven by a multi-pump transmission, provide independent closed-loop hydraulic power for the hoisting drums, boom hoist, swing, left crawler and right crawler. 250 gal hydraulic reservoir is equipped with breather, clean-out access and internal diffuser.

Each function is equipped with relief valves to protect the hydraulic circuit from overload or shock.

System includes oil cooler and replaceable, full flow return filters. All oil is filtered before entering the hydraulic reservoir.

### Drums

Basic machine is equipped with two 49 inch wide and 26 inch diameter main hoist drum, mounted in the boom butt and 4 m insert and 32 inch wide and 25 inch diameter whip drum, mounted in the rotating bed. Each drum is driven by a variable-displacement hydraulic motor through a planetary reduction system. Main hoist drum is grooved for 32 mm rope and whip drum is grooved for 28 mm rope.

Powered hoisting/lowering operation is standard with automatic (spring applied, hydraulically released) multi-disc brakes and drum rotation indicators.

### VPC-MAX® boom hoist

VPC-MAX® is equipped with a 39 inch wide and 22 inch diameter boom hoist drum mounted in the mast butt. The drum is driven by a variable displacement hydraulic motor, through a planetary gearbox with an internal brake. The drum utilizes a ratchet and pawl assembly and is grooved for 28 mm wire rope. Includes 28 mm wire rope for 16-part boom hoist reeving.

### Moving mast system

Independent moving mast hoist with two grooved drums, each 19 inch wide and 31 inch diameter drum grooved for 32 mm. Includes 32 mm wire rope for 30-part boom hoist reeving.

Drum is powered by variable-displacement hydraulic motors coupled to internal brake and planetary reduction gearboxes. Ratcheting pawl and rotation indicator are standard.

Raise 341.2 ft main boom from 0° - 85° in 7 minutes and 40 seconds.

### Boom support system

Moving mast is 36 ft long and connects the boom hoist reeving to the steel boom suspension strap rigging. When used with the optional self-erect package, the mast is used for crane assembly and disassembly. It is capable of lifting and positioning the crawler assemblies, and assembling the boom and luffing jib. Spring-cushioned boom stop and automatic boom stop are standard.

### Variable Position Counterweight

The Variable Position Counterweight (VPC®) system of rotating bed only counterweight maintains optimum crane stability by automatically positioning crane counterweight based on boom angle and length. No carbody counterweight is required.

The crane can be equipped with 881,800 lb upperworks only counterweight made up of a single piece counterweight tray and 38 22,000 lb counterweight boxes. Left and right side counterweights are interchangeable and common with MLC300 counterweight.

### Vision operator's cab

The Vision Cab™ is a fully enclosed and insulated galvanized steel fabricated module mounted to the left front corner of rotating bed. Operator's cab is equipped with power tilt, sliding door, large safety glass windows, front and roof windshield wipers, dome light, sun visor and shade, fire extinguisher, air conditioning, swing and travel alarms, and radio/CD player. Operator's station swings over front of rotating bed for transportation.

**Optional:** Polyethylene protective window covers.

## Lowerworks

### Carbody and adapter assembly

Connects rotating bed and crawler frames. Each frame is mounted to the carbody with FACT™ connection system and hydraulic power-actuated pins. Crawler drive motors are mounted on carbody, permitting crawler removal without opening travel drive hydraulic circuit.

### Crawlers

Crawler assemblies are 36 ft long with 60 inch wide cast steel crawler pads and automatically lubricated intermediate rollers. Left and right side crawlers are interchangeable to provide assembly/disassembly flexibility on jobsites. Carbody mounted drive motors are connected to crawler final reduction via drive shafts. Crawlers provide ample tractive effort for travel and counter-rotating with full rated load.

Maximum ground speed of 0.8 mph.

**Optional:** 80 inch wide cast steel crawler pads.

## Attachments

### B10: 680 boom

The liftcrane is equipped with 105.0 ft 680 basic boom consisting of 19.7 ft butt, 13.1 ft insert, 39.4 ft insert with luffing hoist sheaves, and 32.8 ft top with 16 30 inch diameter tapered roller bearing sheaves. Includes rope guides, boom hoist wire rope, boom angle indicator and hook and weight ball. The boom utilizes Manitowoc's exclusive FACT connection system boom connector. Spring-cushioned boom stop. Automatic boom stop.

**Optional:** 19.7 ft and 39.4 ft No. 680 boom inserts with steel boom suspension straps and FACT connection system.

**Optional:** detachable upper boom point with one 30 inch diameter tapered roller bearing steel sheave grooved for 32 mm rope with rope guard for liftcrane.

# Specifications

## Attachments *(cont'd)*



### No. 148 fixed jib

39.4 ft No. 148 fixed jib including pin 19.7 ft butt, 19.7 ft top, jib strut and mounting hardware.

**Optional:** 19.7 ft and 39.4 ft No. 148 inserts with pin connectors and pendants for a maximum jib length of 137.8 ft.



### LJ:10 681-682 luffing jib

85.3 ft basic LJ10: 681-682 luffing jib including 6 m butt, one 12 m insert, 19.7 ft transition insert and 6.6 ft top, main and jib struts, jib and backstay steel suspension straps, upper boom point guide wheel, luffing jib hoist with ratchet and pawl; quick disconnect for jib hoist piping and 28 mm luffing jib hoist line.

**Optional:** 9.8 ft, 19.7 ft and 39.4 ft No. 681 and 682 luffing jib inserts with steel boom suspension straps. Utilize luffing jib inserts in combination with the LJ10: 681-682 basic luffing jib for total luffing jib lengths up to 331.3 ft.



### VPC-MAX®

The VPC-MAX® components include:

- 118 ft of No. 684 mast consisting of a 19.7 ft butt, (2) 39.4 ft inserts and a 19.7 ft top.
- One additional swing drive (for a total of three) mounted on the adapter frame. Each swing drive is powered by a fixed-displacement hydraulic motor coupled to a planetary reduction gearbox and internal brake.

The VPC-MAX® system maintains optimum crane stability by automatically positioning crane counterweight behind the crane's centerline of rotation based on lifted load, boom length and load radius.

## Optional Equipment

Self-erect system includes, jacking cylinders with pads, self assembly cylinder and crawler handling chains.

- Hydraulic Test Kit: required to properly analyze the performance of the CCS.
- Service Interval Kits for the regularly scheduled maintenance of general crane operations.
- Special paint color(s) other than Manitowoc standard red and black.
- Custom vinyl decal(s) of customer name and/or logo from artwork supplied by customer.
- 24.5 USt swivel hook and weight ball.
- Carbody jacking cylinders to allow 360° swing with crawler assembly during self erect.

For complete charts and supporting documentation, visit the Lattice Boom Crane Library: <https://www.manitowoc.com/support/lattice-boom-crane-library> or scan the QR code.



# Notes

# The Manitowoc Company, Inc.

## Regional headquarters

### Americas

Milwaukee, Wisconsin, USA  
Tel: +1 414 760 4600

Shady Grove, Pennsylvania, USA  
Tel: +1 717 597 8121

### Europe and Africa

Dardilly, France - TOWERS  
Tel: +33 (0) 4 72 18 20 20

Wilhelmshaven, Germany - MOBILE  
Tel: +49 (0) 4421 294 0

### APAC

Shanghai, China  
Tel: +86 21 6457 0066

Singapore  
Tel: +65 6264 1188

### Middle East and India

Dubai, UAE  
Tel: +971 4 8862677

This document is non-contractual. Constant improvement and engineering progress make it necessary that we reserve the right to make specification, equipment, and price changes without notice. Illustrations shown may include optional equipment and accessories and may not include all standard equipment.

